

Joseph Lstiburek, Ph.D., P.Eng, ASHRAE Fellow

Building Science 2009

Ventilating a Tight Home

presented by www.buildingscience.com

Air Barrier Metrics

Material	0.02 l/(s-m ²)@75 Pa
Assembly	0.20 l/(s-m ²)@75 Pa
Enclosure	2.00 l/(s-m ²)@75 Pa

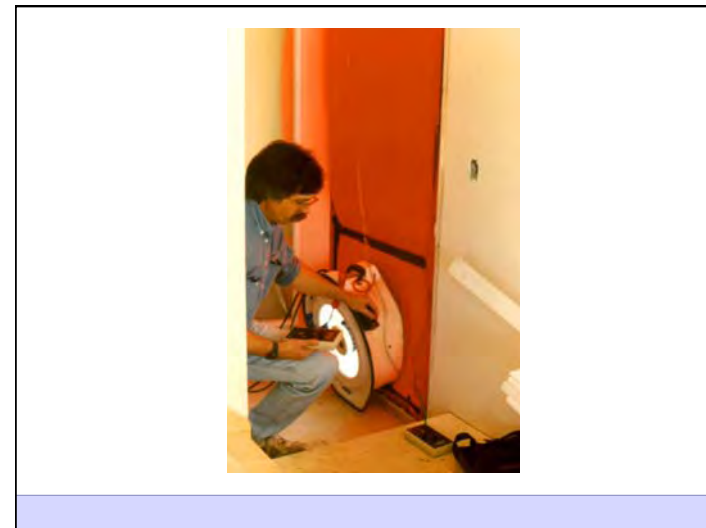
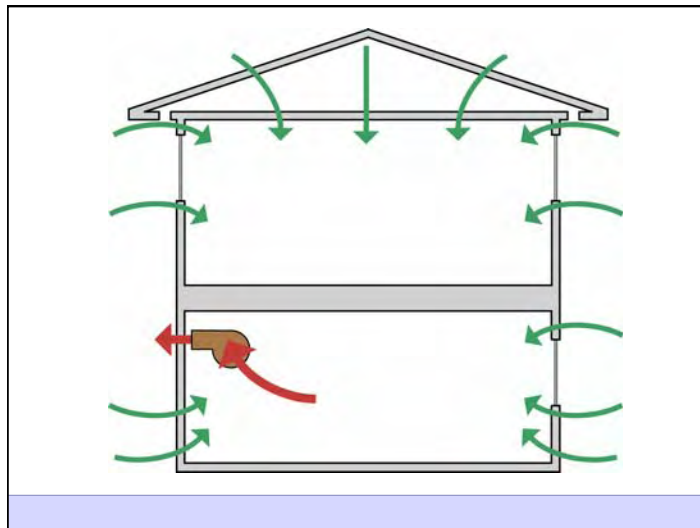

Ventilating a Tight Home

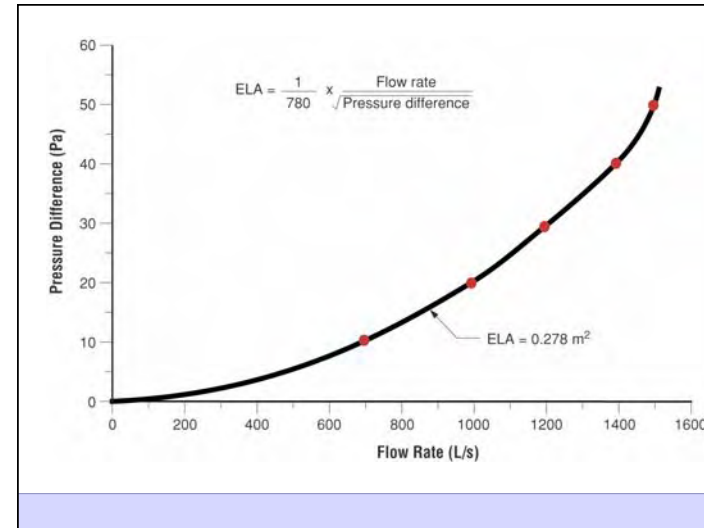
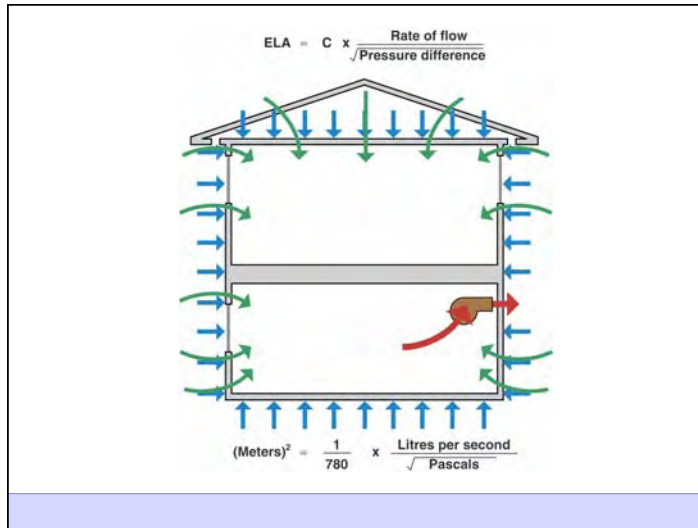

Duct Leakage Should Be Less Than 5% of Rated Flow As Tested by Pressurization To 25 Pascals



Sealed Combustion Appliances





Three Types of Controlled Ventilation Systems

- Exhaust Ventilation
- Supply Ventilation
- Balanced Ventilation

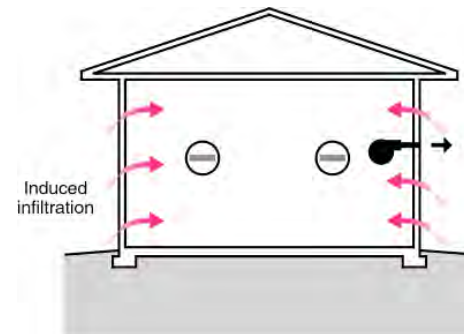

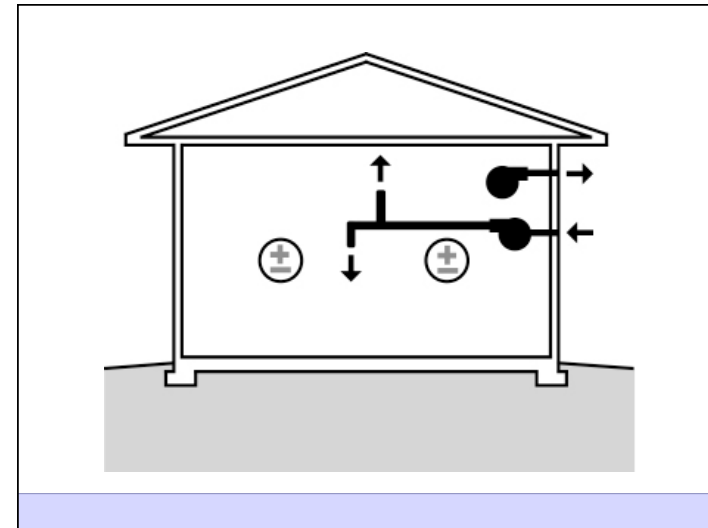
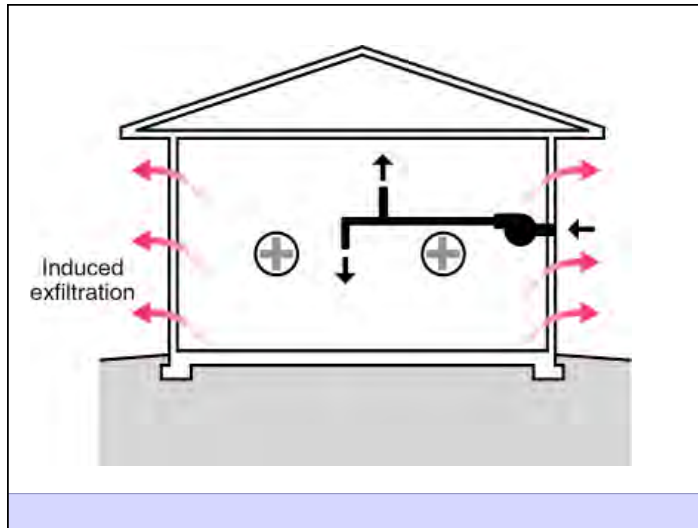

ASHRAE Standard 62.2 calls for 7.5 cfm per person plus 0.01 cfm per square foot of conditioned area

Occupancy is deemed to be the number of bedrooms plus one

Occupant Rate + Building Rate

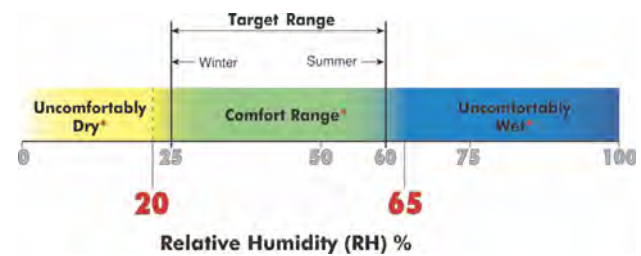

Recommended Range of Relative Humidity
25 percent during winter
60 percent during summer

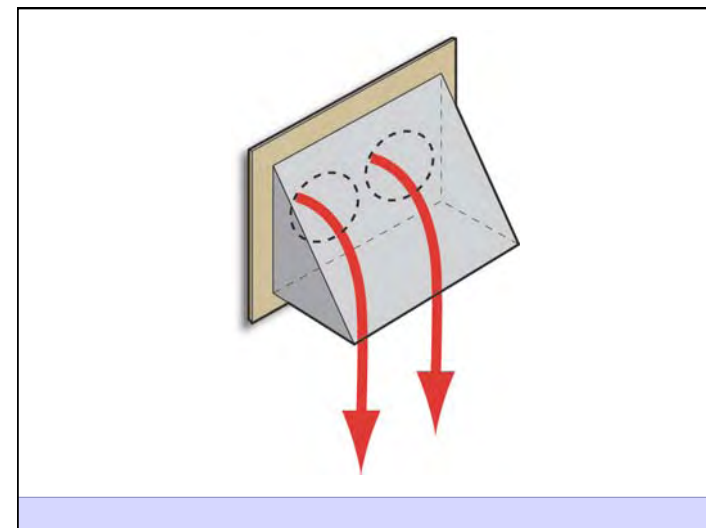
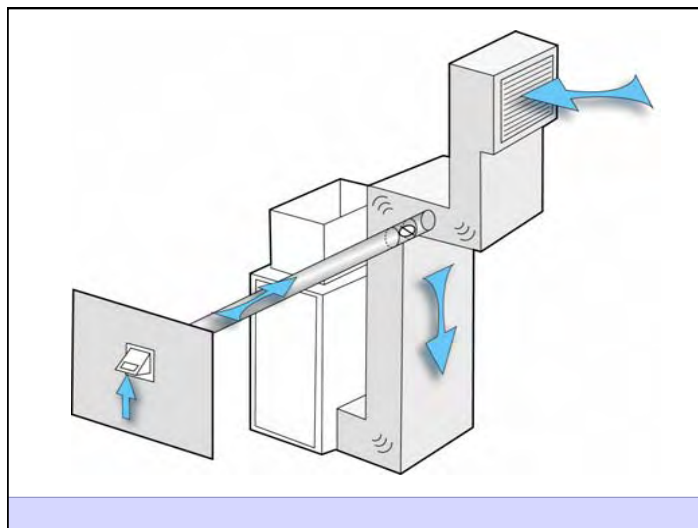
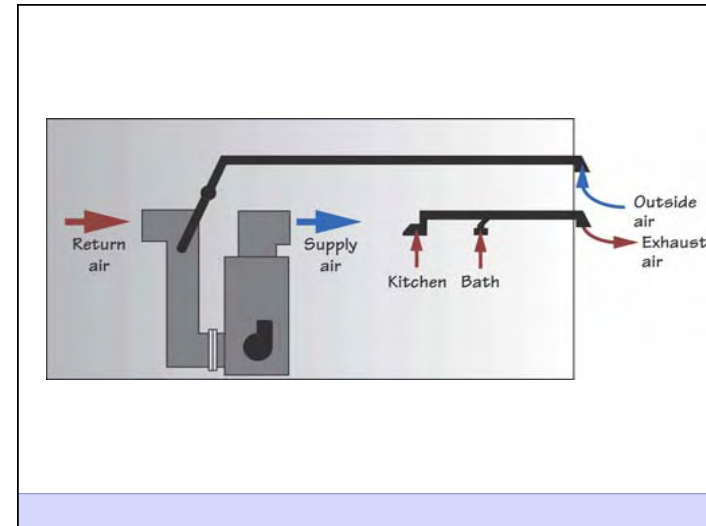

Ventilating a Tight Home

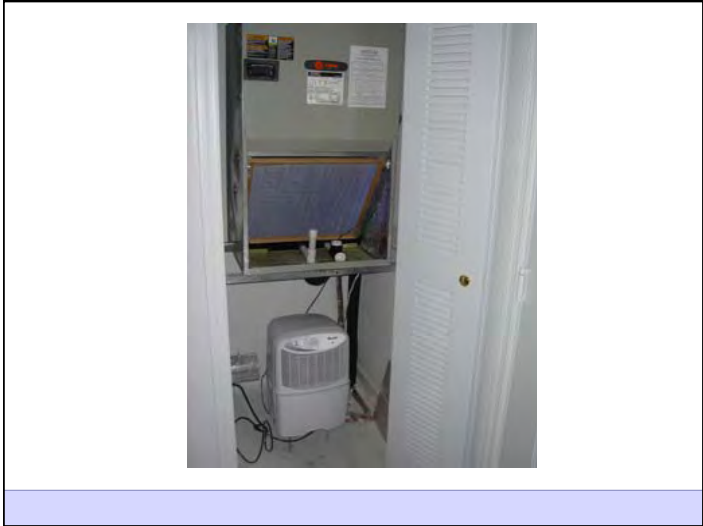
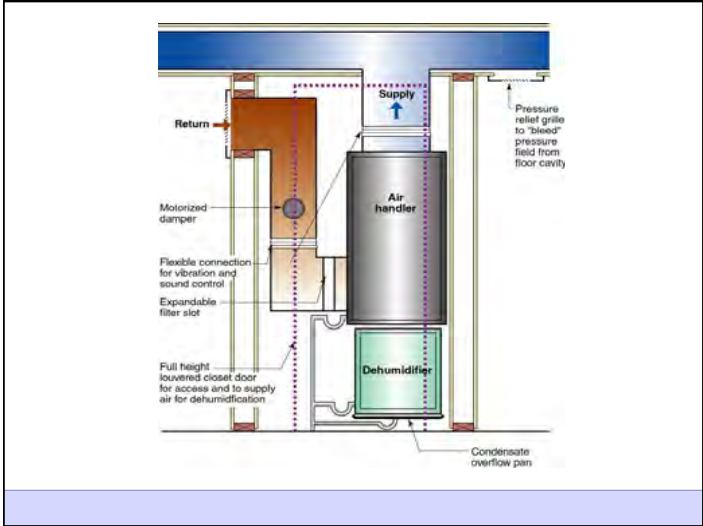
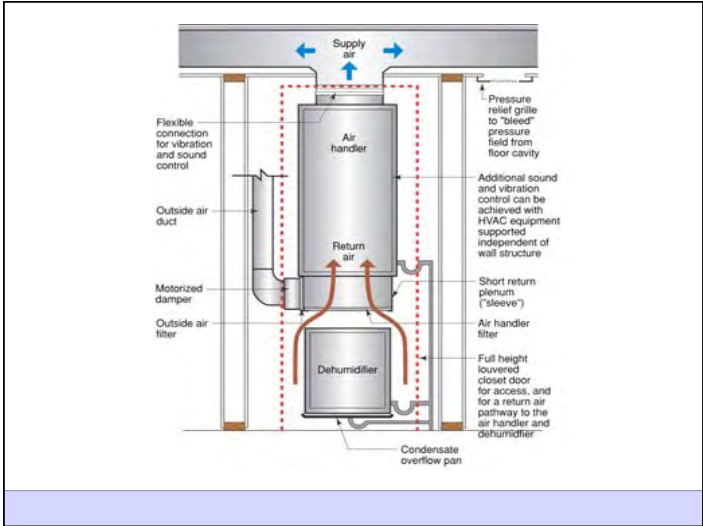
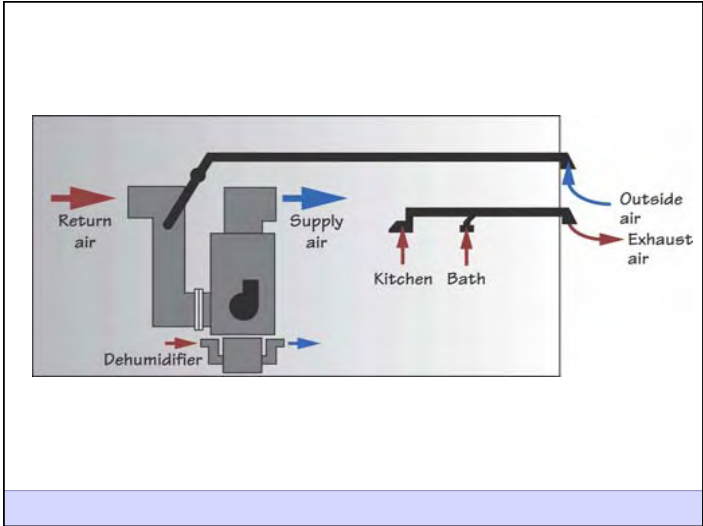

Ventilating a Tight Home

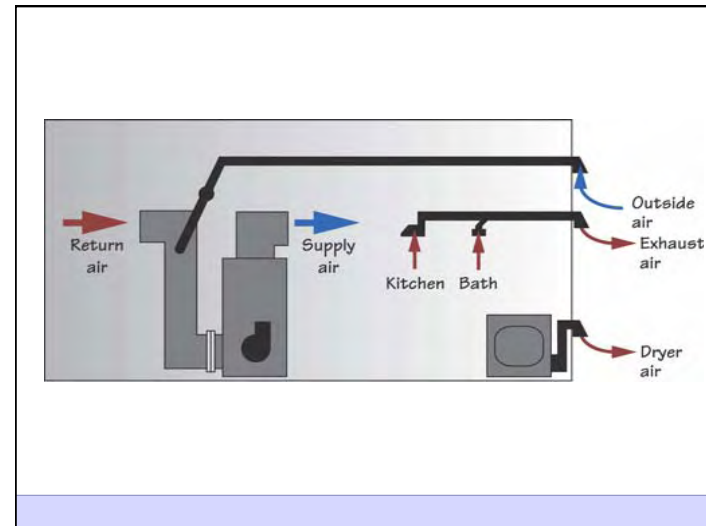
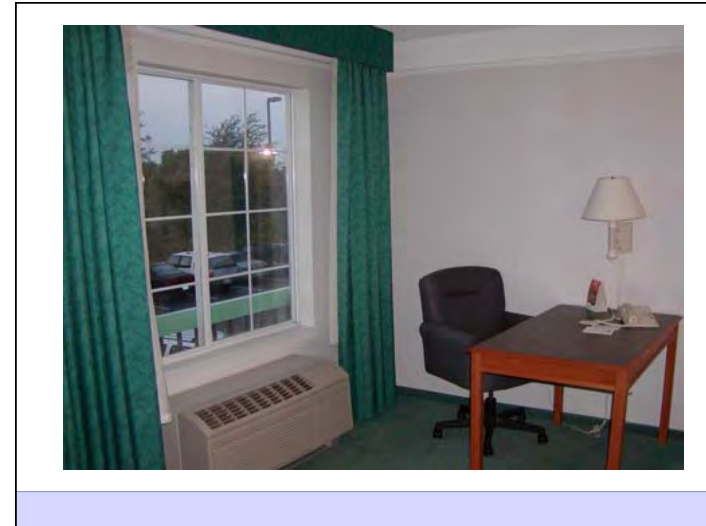

Ventilating a Tight Home

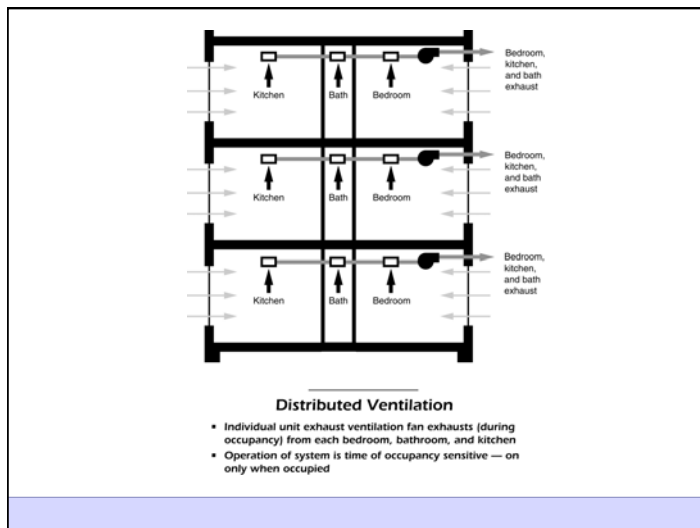
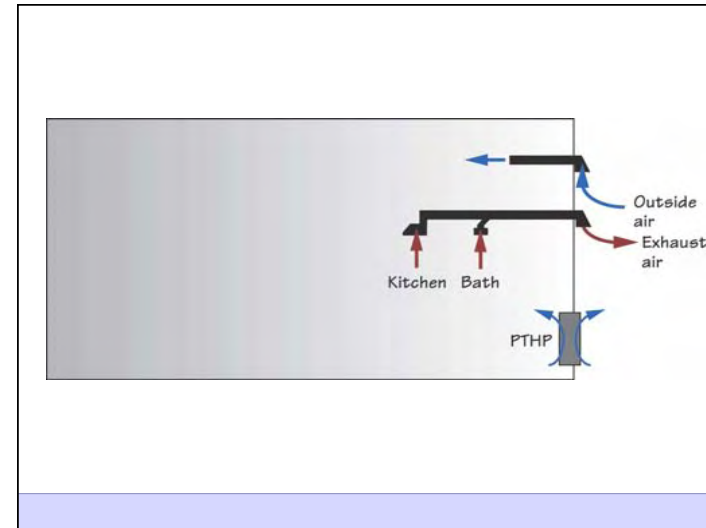
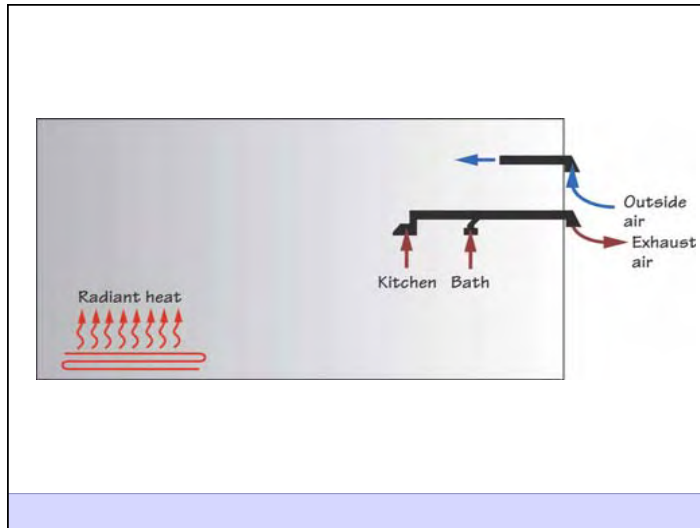

Ventilating a Tight Home

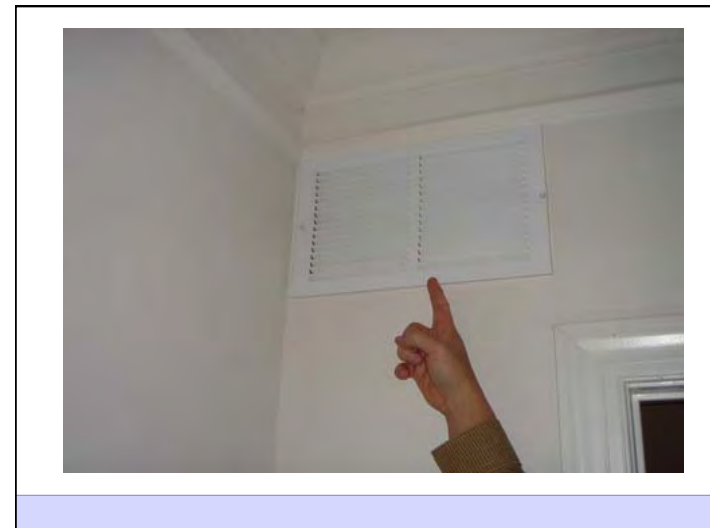
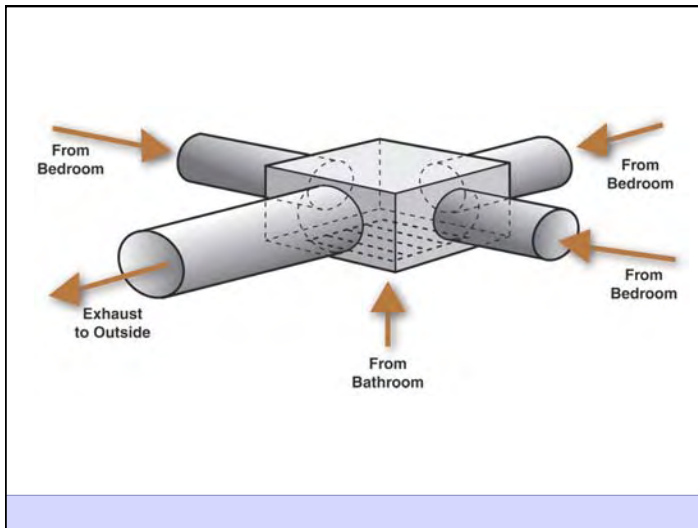
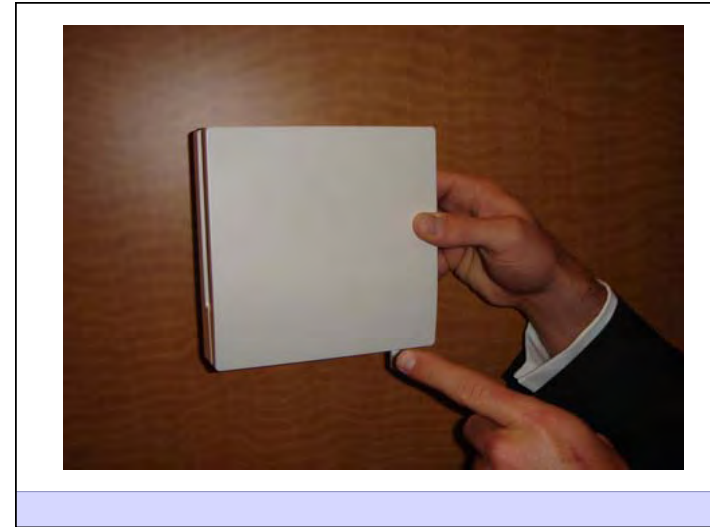
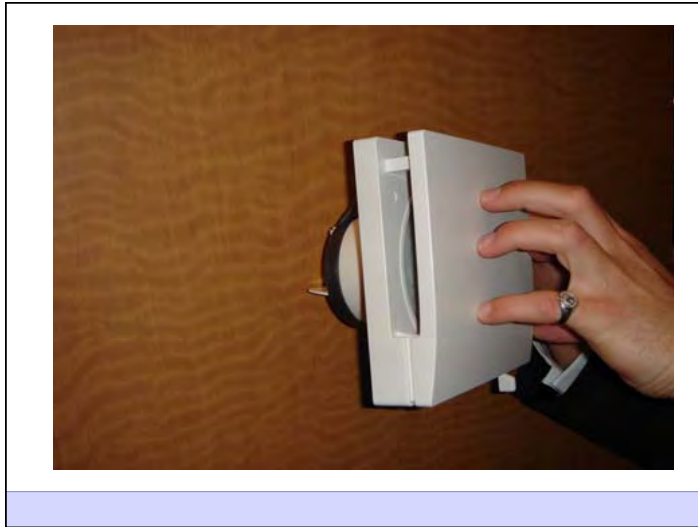

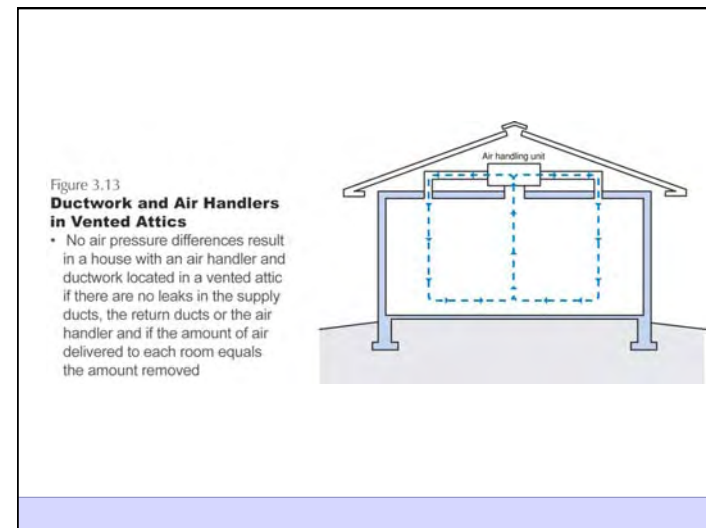
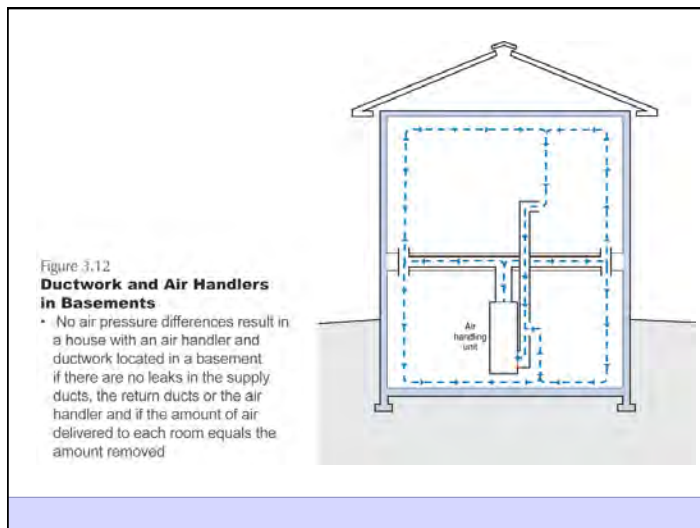
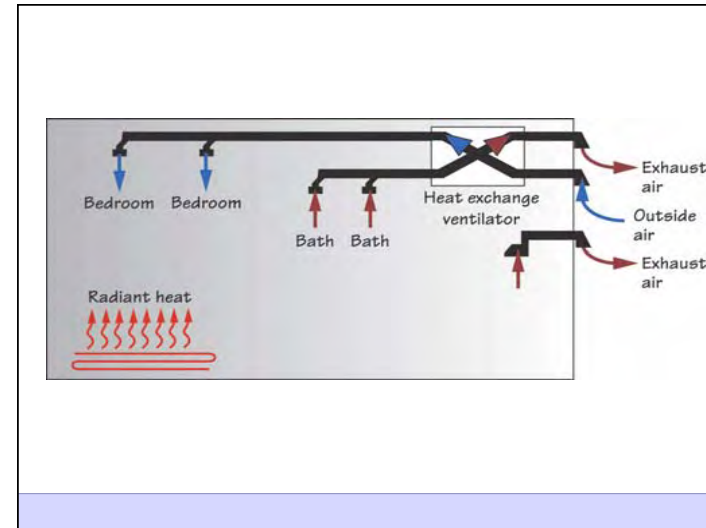
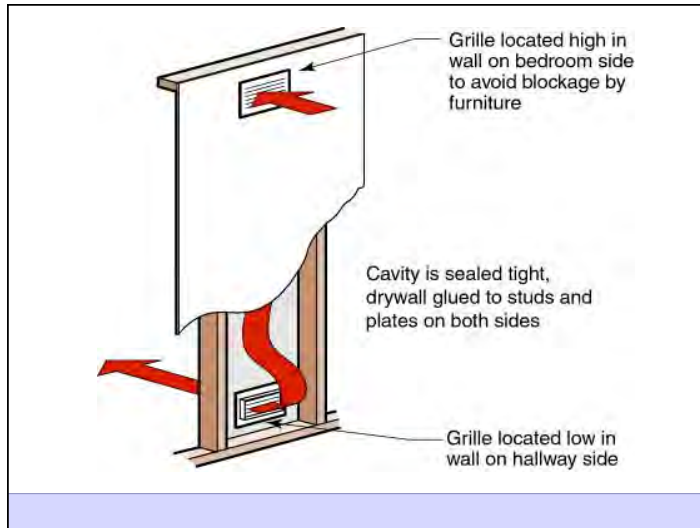

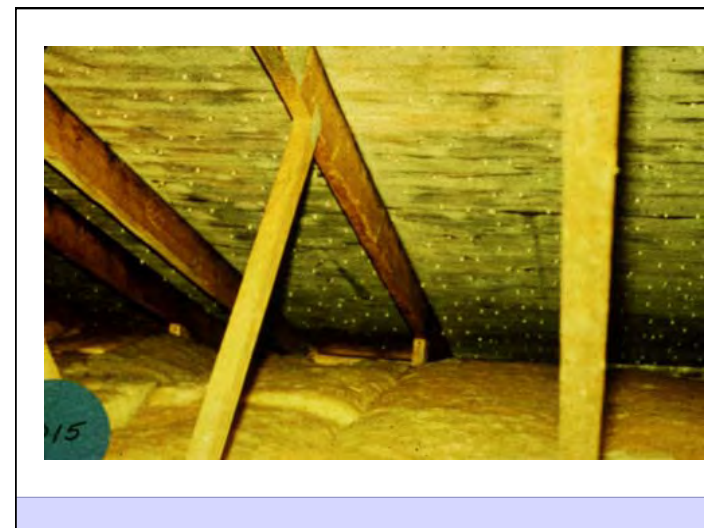
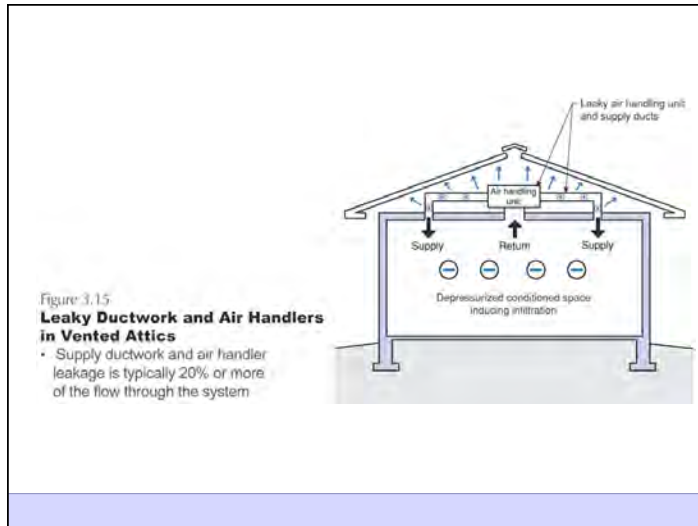

Ventilating a Tight Home

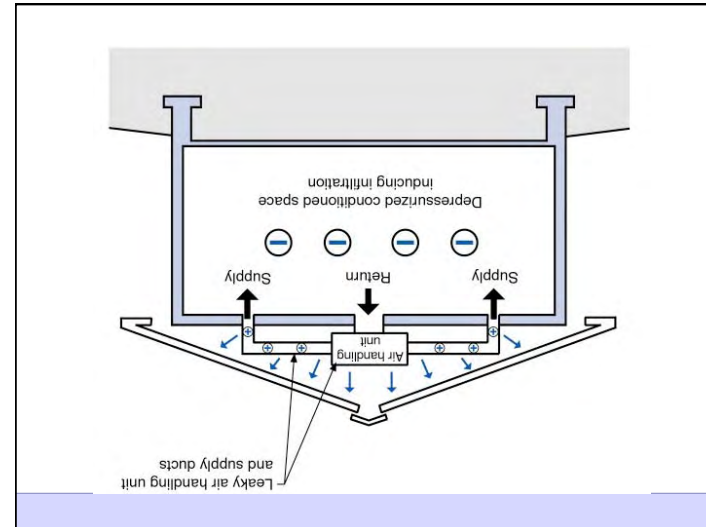
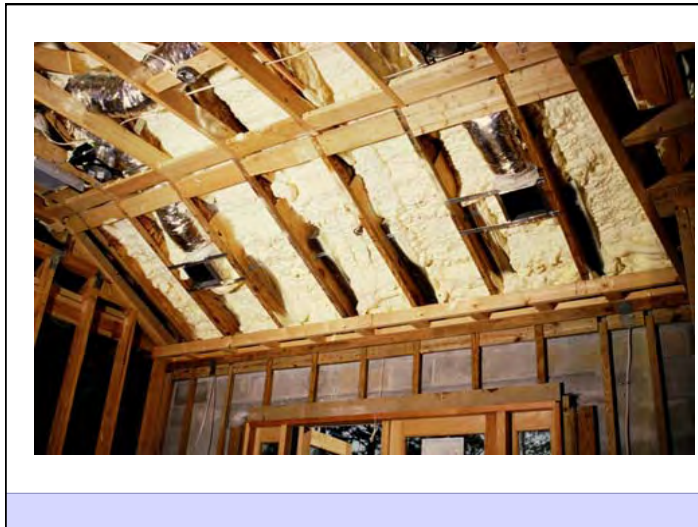
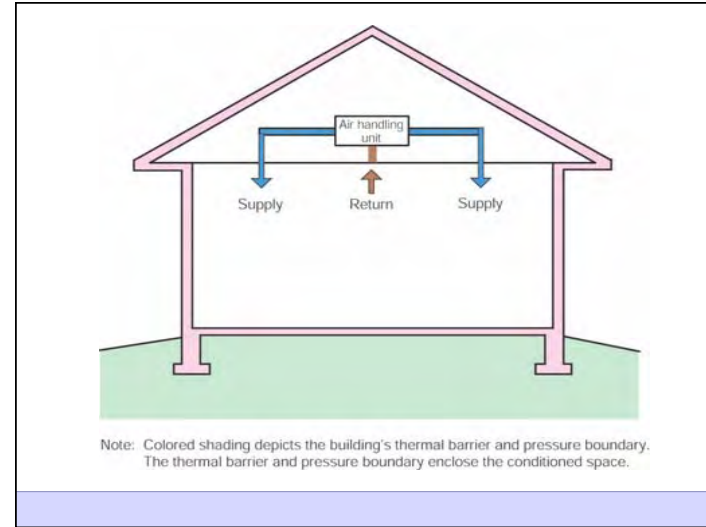

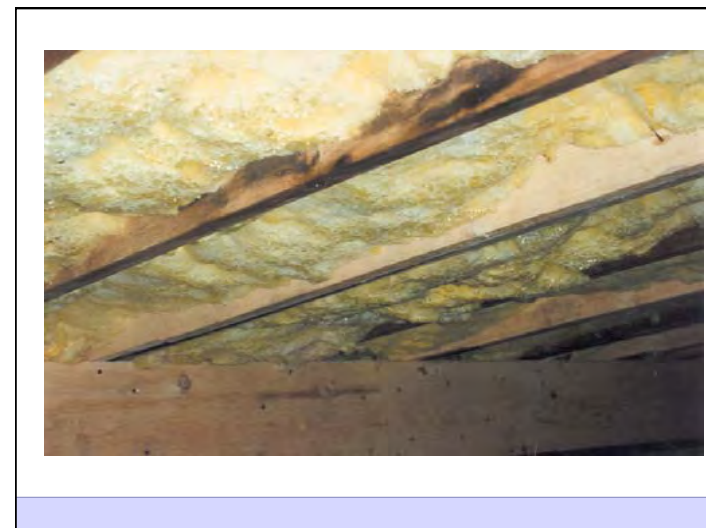
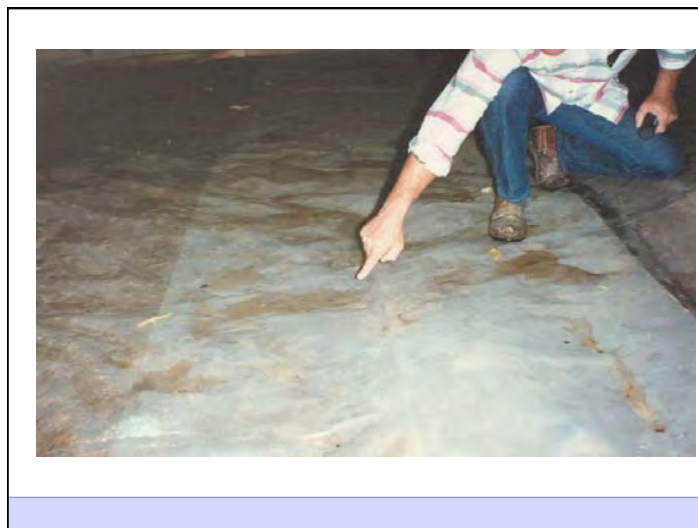
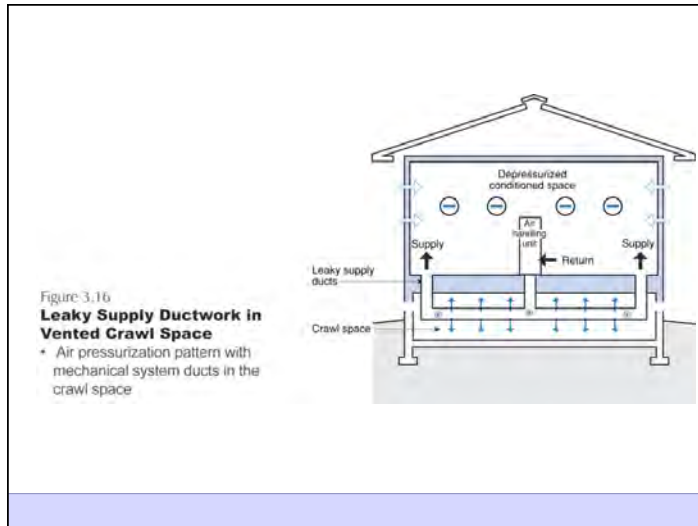

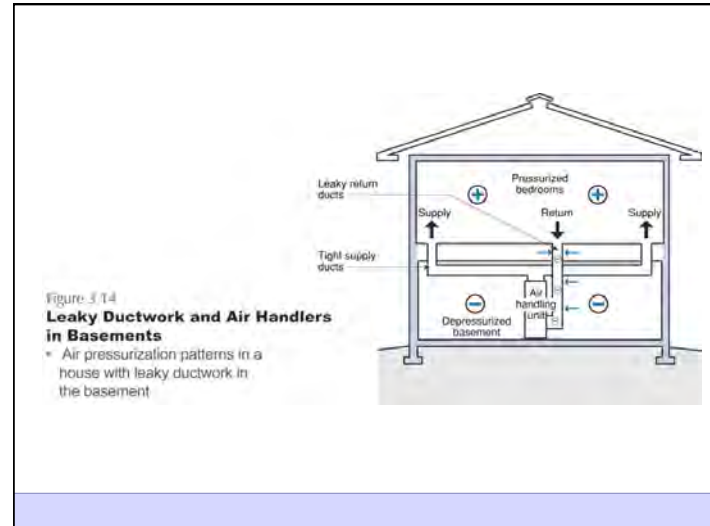
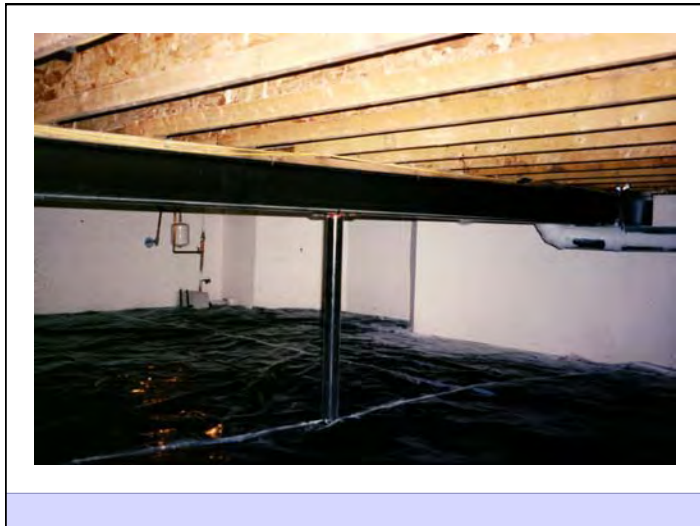
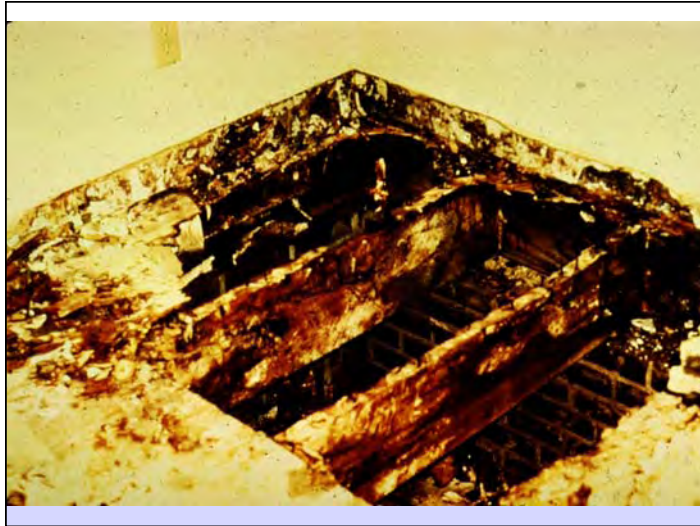

Ventilating a Tight Home

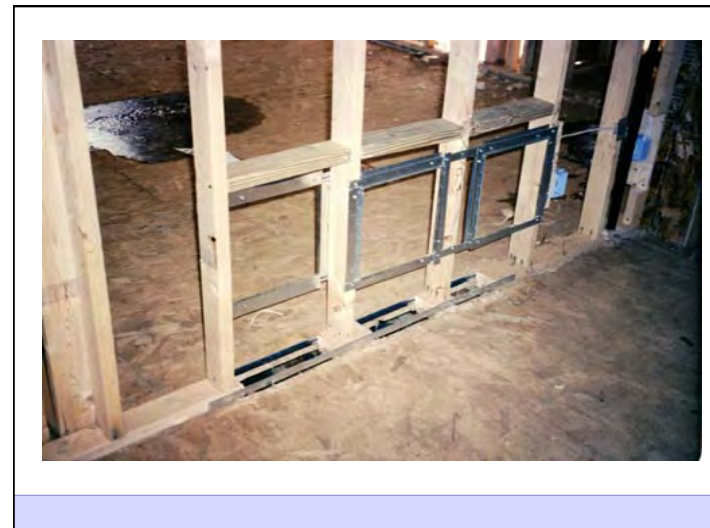
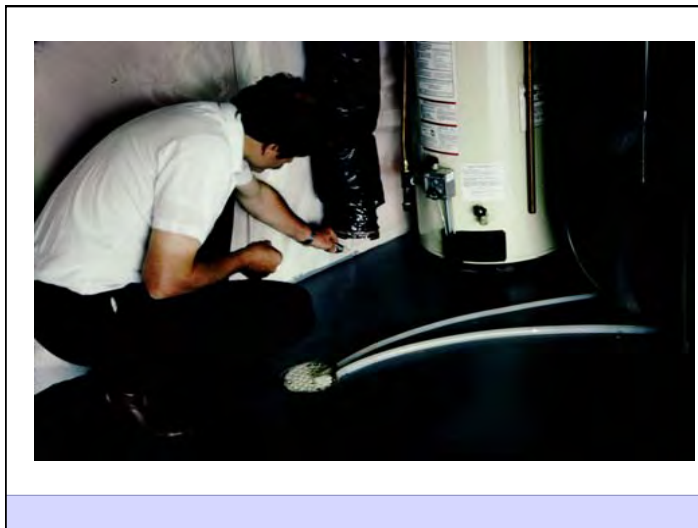
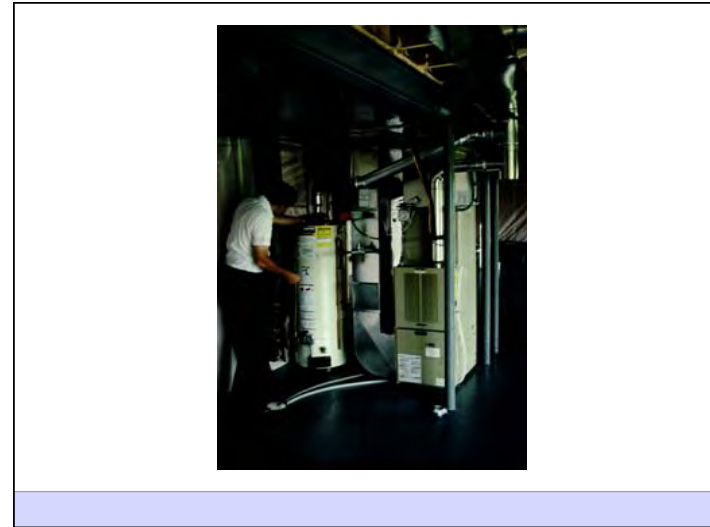
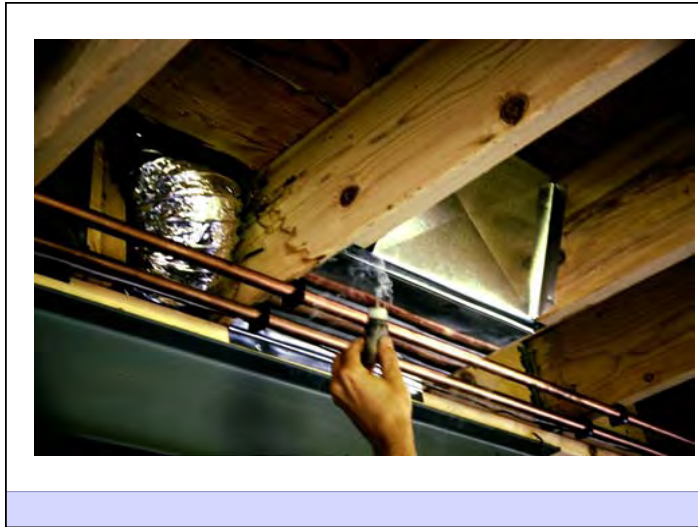

Ventilating a Tight Home

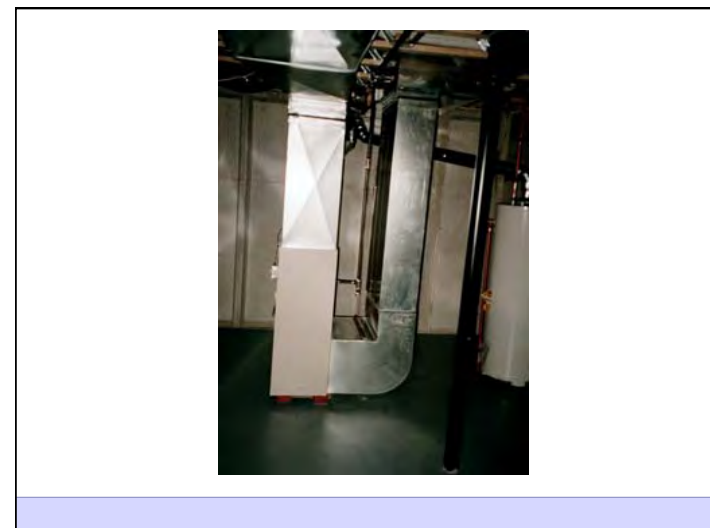
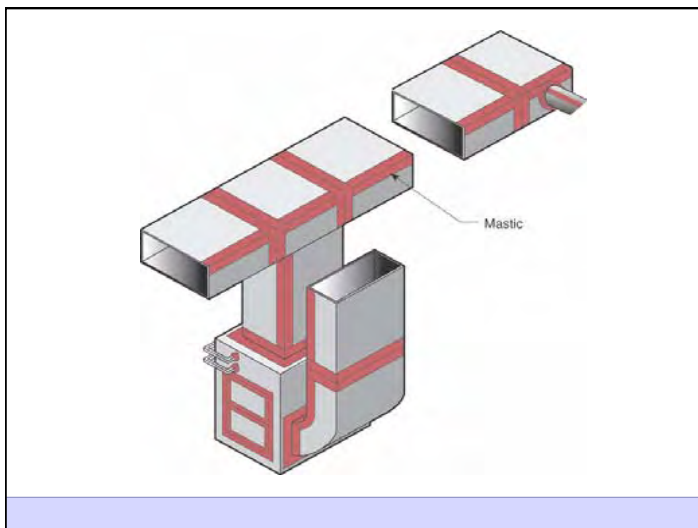
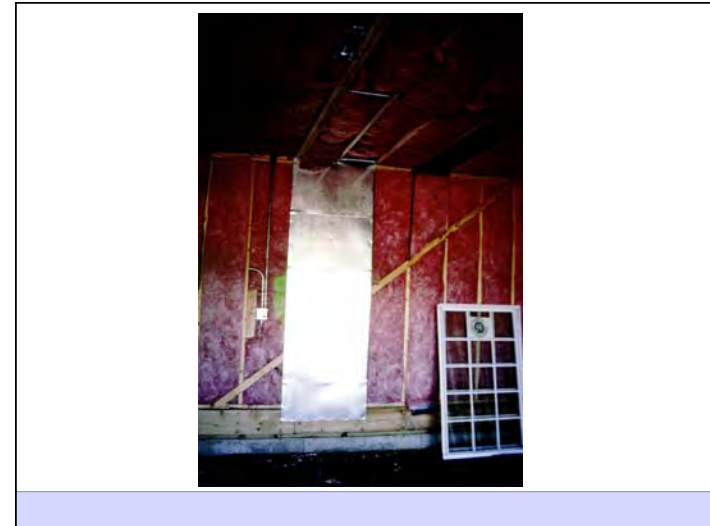
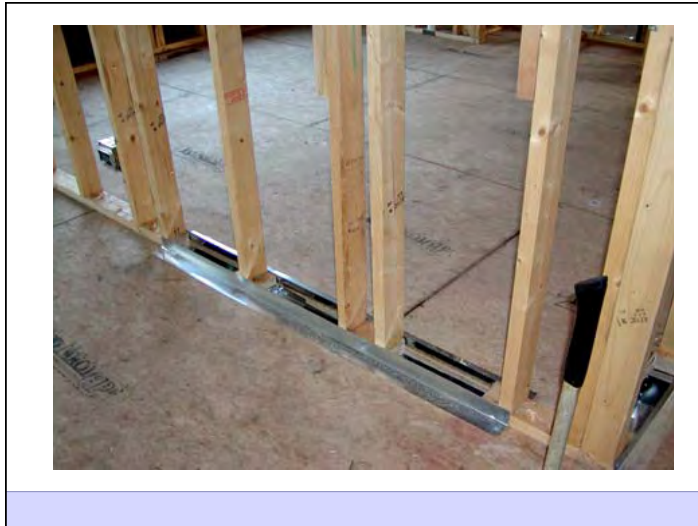
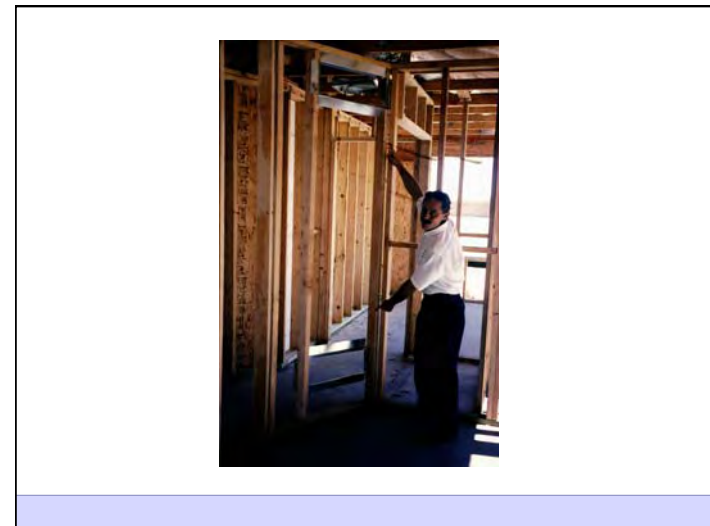
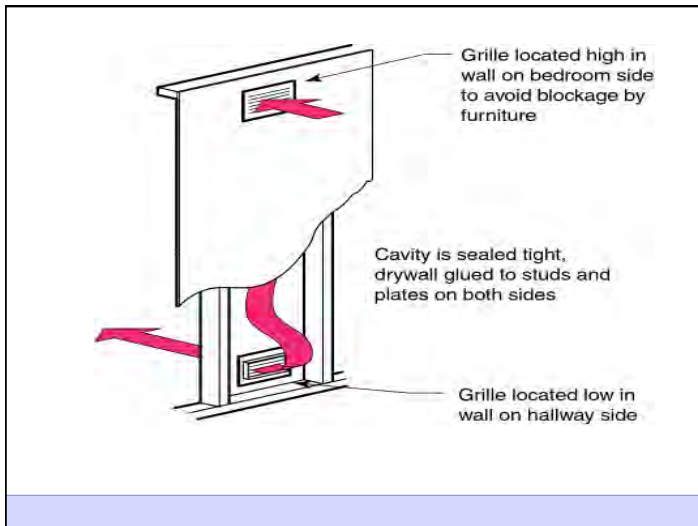

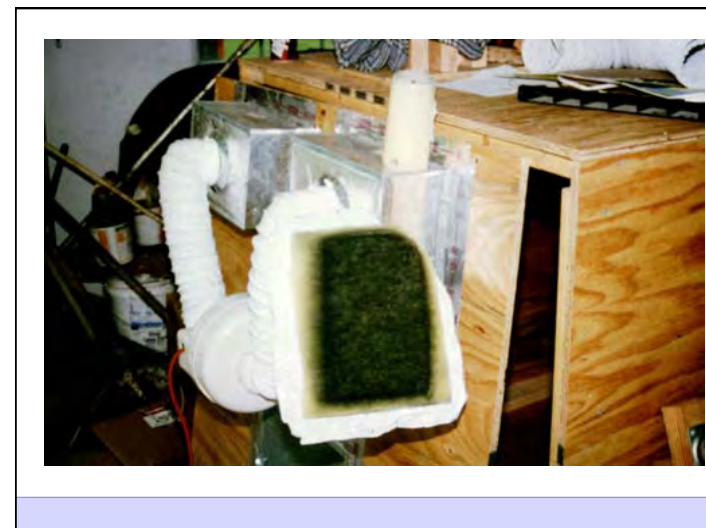
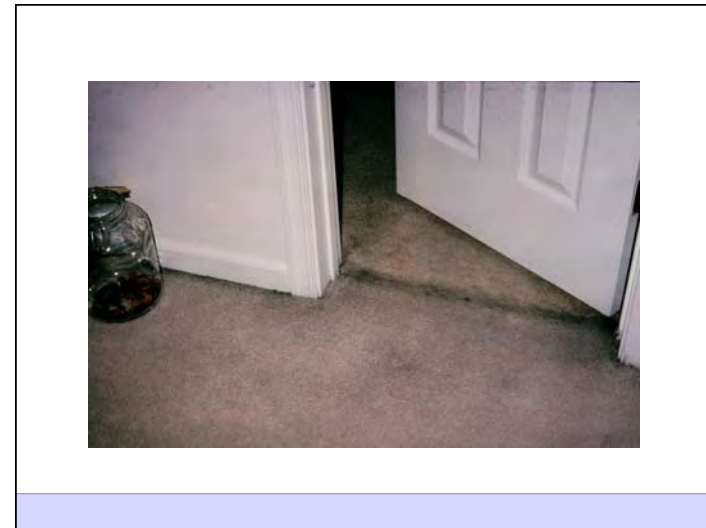
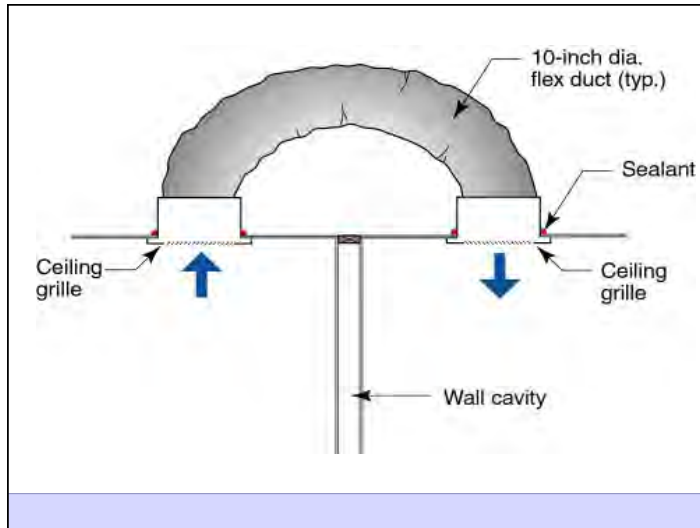

Figure 3.18
Insufficient Return Air Paths

- Pressurization of bedrooms often occurs if insufficient return pathways are provided; undercutting bedroom doors is usually insufficient; transfer grilles, jump ducts or fully ducted returns may be necessary to prevent pressurization of bedrooms
- Master bedroom suites are often the most pressurized as they typically receive the most supply air
- When bedrooms pressurized, common areas depressurize; this can have serious consequences when fireplaces are located in common areas and subsequently backdraft



Ventilating a Tight Home



Ventilating a Tight Home

