

Building Science
Rain Control

presented by www.buildingscience.com

- ### Rain
- Rain is the largest source of moisture
 - We need better control for better insulation and airtightness
 - Rain penetration control
 - Site and massing
 - Surface features
 - Enclosure wall strategy

Controlling Rain Penetration

- **Deflection**
 - reduce water on building
 - redirect water away
 - slope surfaces, use flashing
- **Drainage / Exclusion / Storage**
 - enclosure design
 - provide drainage, or storage or barrier
- **Drying**
 - allow any remaining water to dry

Deflection

- **Surface & site features are also important**

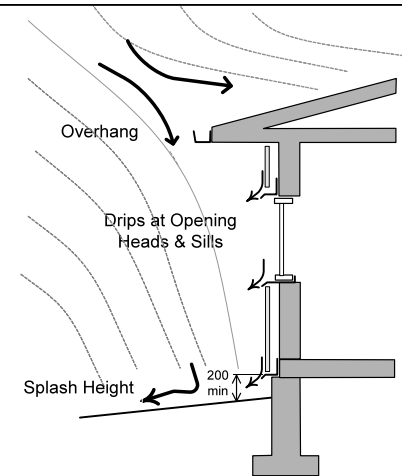



Building Science

Rain Control 13

Claddings that leak

- Brick
- Stucco
- Wood, vinyl, fiber cement
- Adhered veneer
- EIFS
- Metal panels, metal roofs
- Shakes, shingles

Building Science

Rain Control 14

Drainage

- Must have **continuous drainage plane**
- Drainage plane must be:
 1. Water tolerant
 2. Capillary inactive (water repellent / non-wicking)
- Small **gap** required
 - As small as 1 mm
- **Flashing** is very important
- **Weep holes**

Terms: sheathing membrane, building paper, housewrap,
Stupid terms: *weather resistant barrier (WRB)*

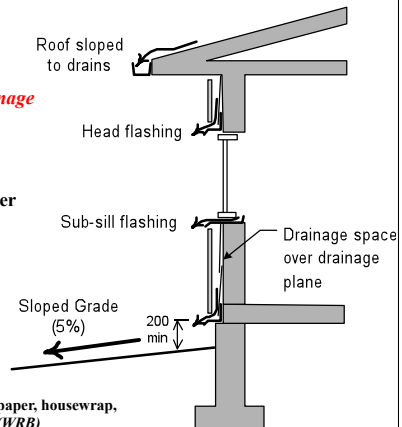

Requirements Drained Walls

- Drainage plane
 - Water repellent, continuous
- Drainage gap
 - 1/16" is enough!
- Flashing
 - Waterproof to direct water outward
- Weep holes
 - Above grade

Building Science

Rain Control 16

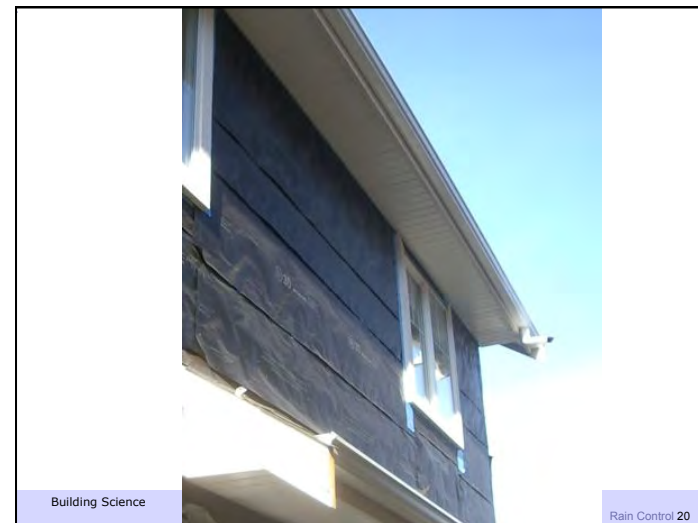
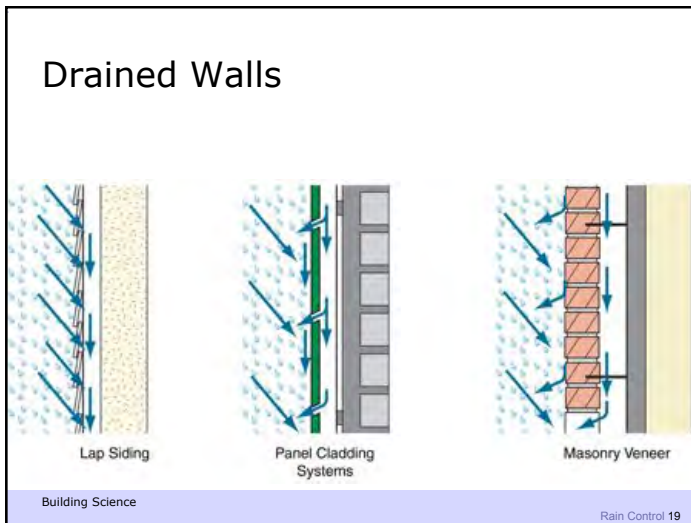
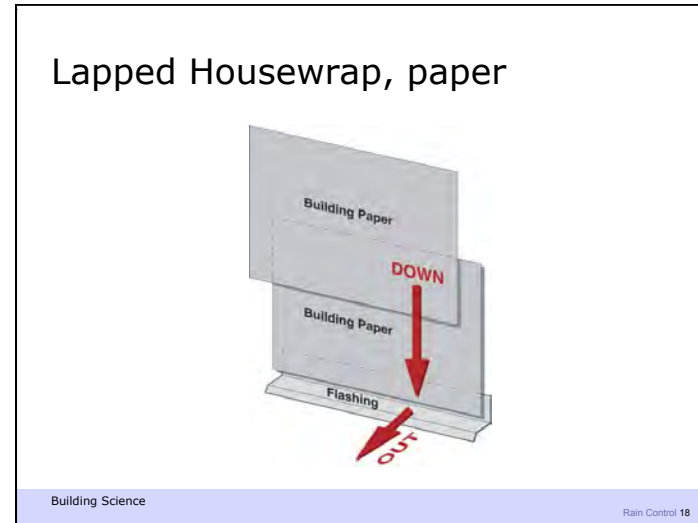
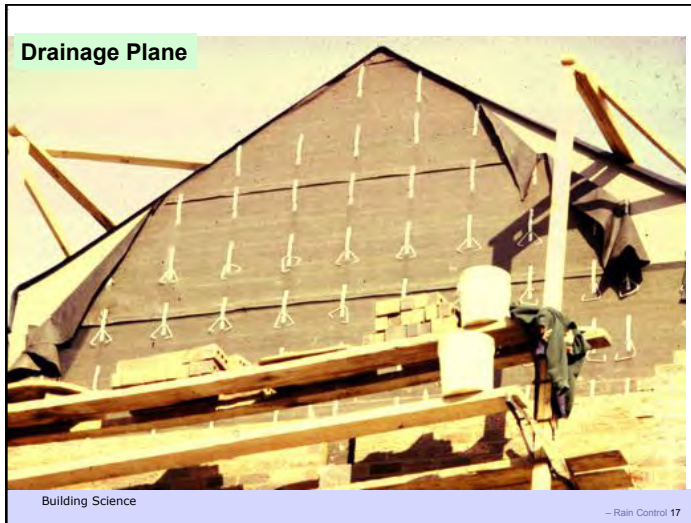

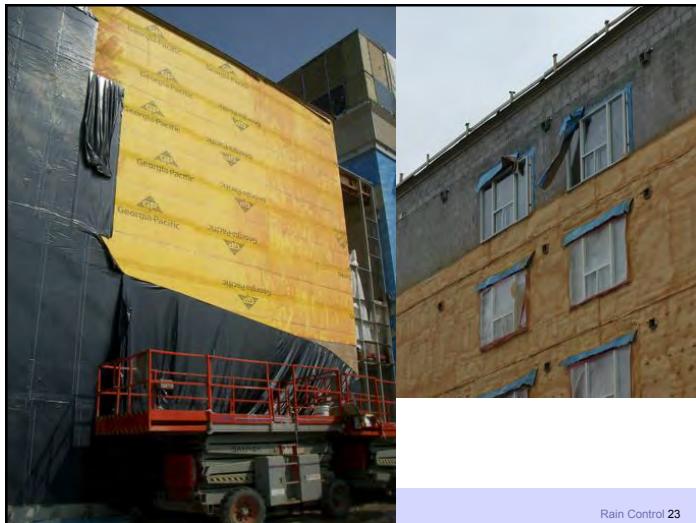





Drainage Gaps

- Gap avoids hydrostatic pressure
 - drains away water
 - Requires only small gap, e.g. 1/16"
- Reduces time of wetness on housewrap sheathing membrane
- *May* allow ventilation drying if >1/8"-1/2"

30



Stucco sticks to paper/ housewraps



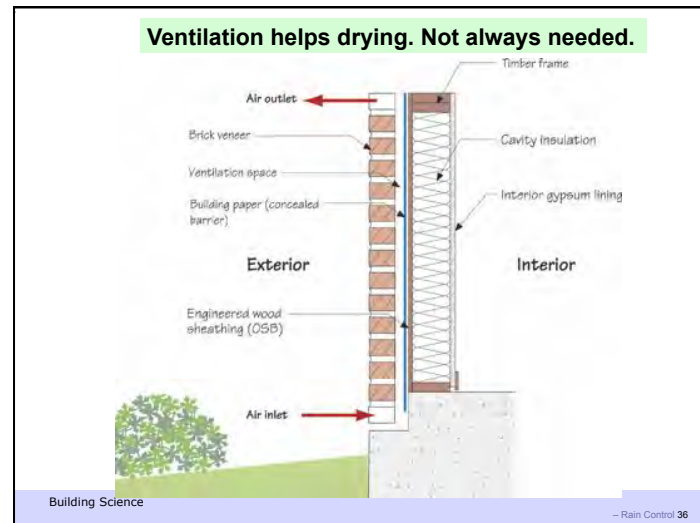

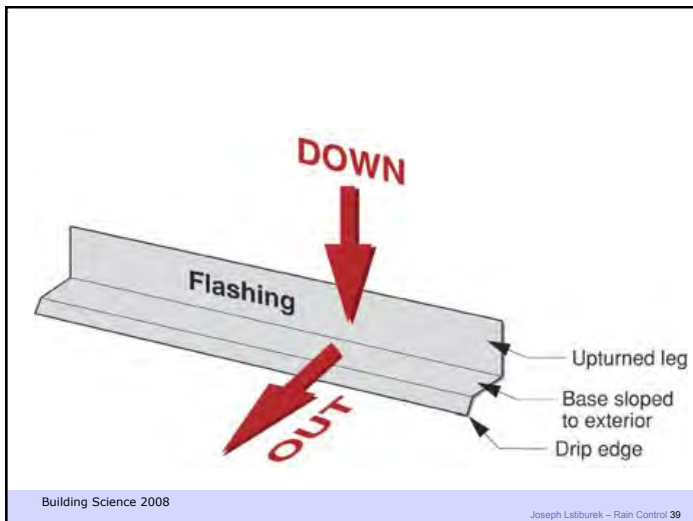
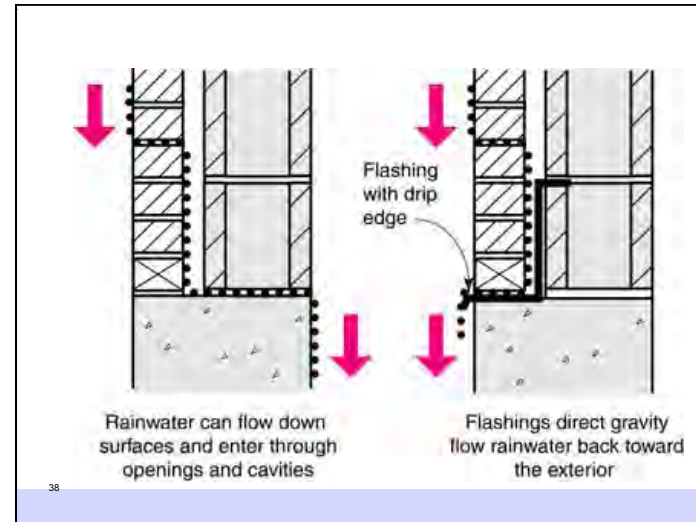

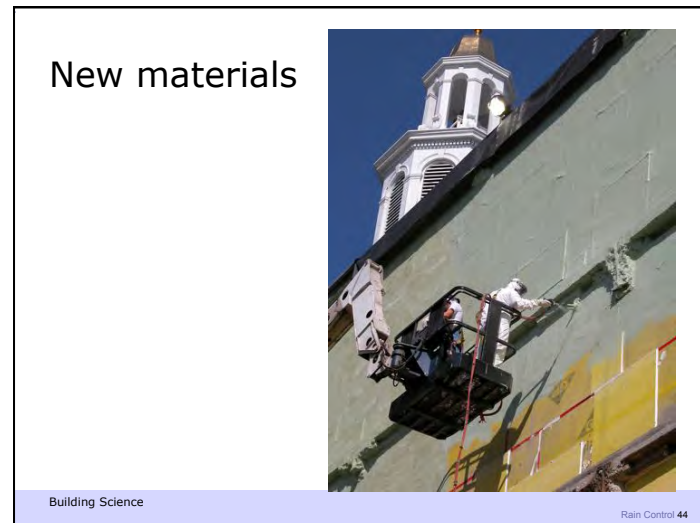
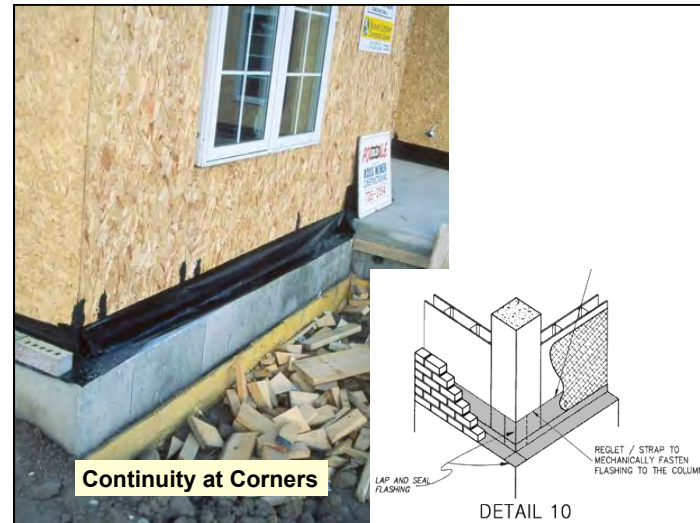
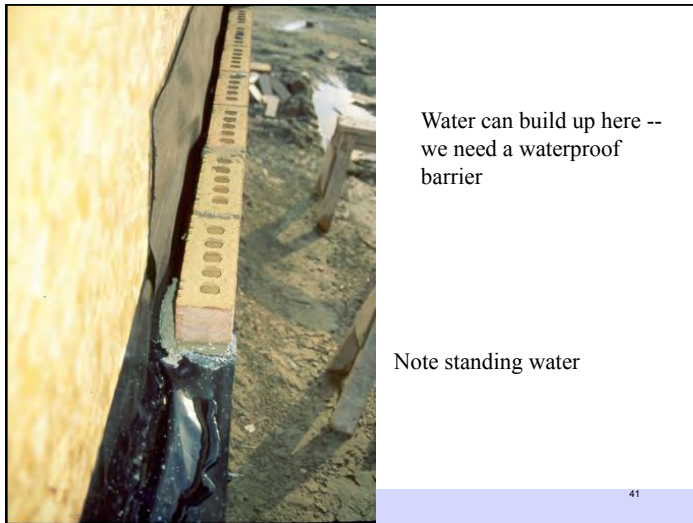

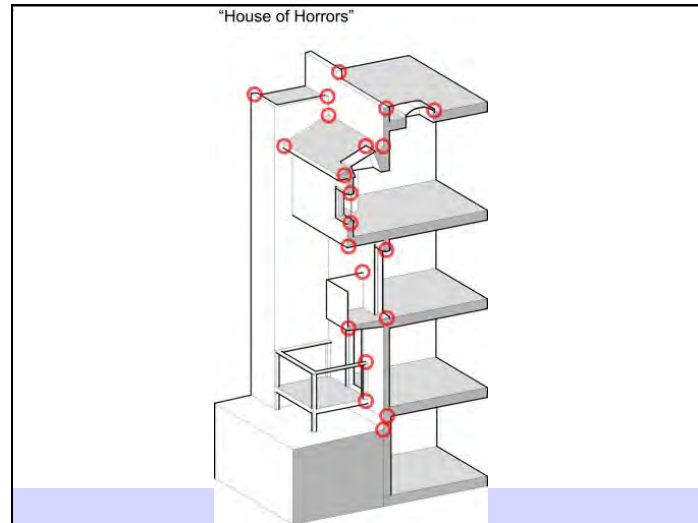

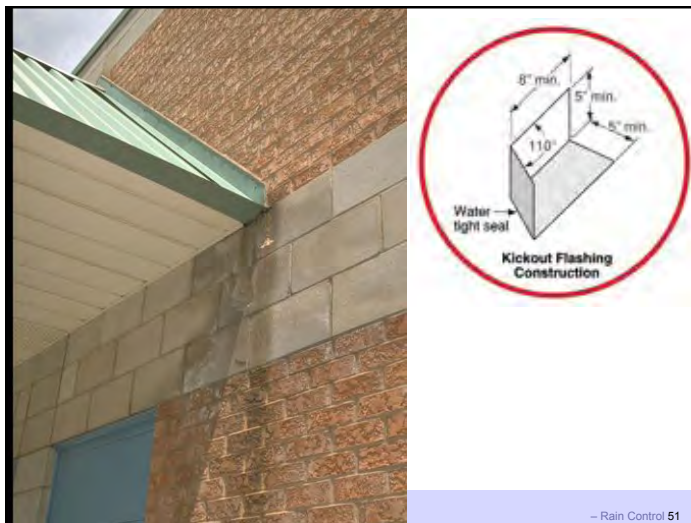
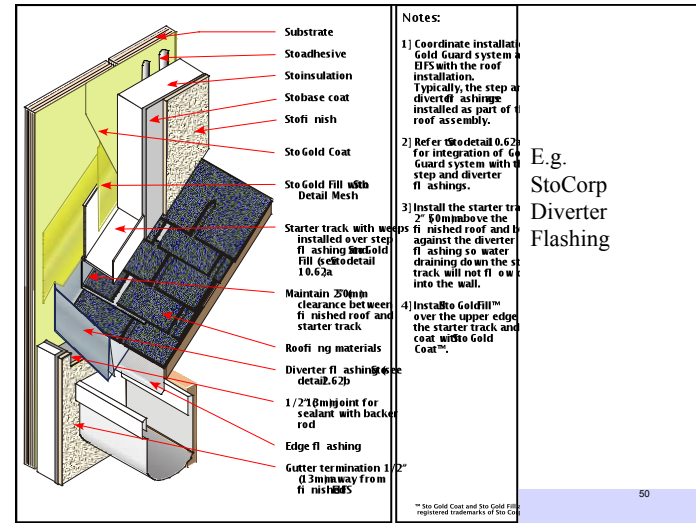

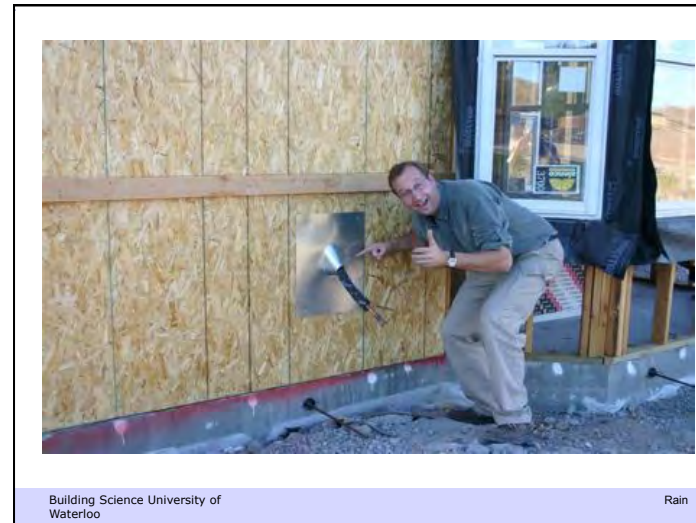
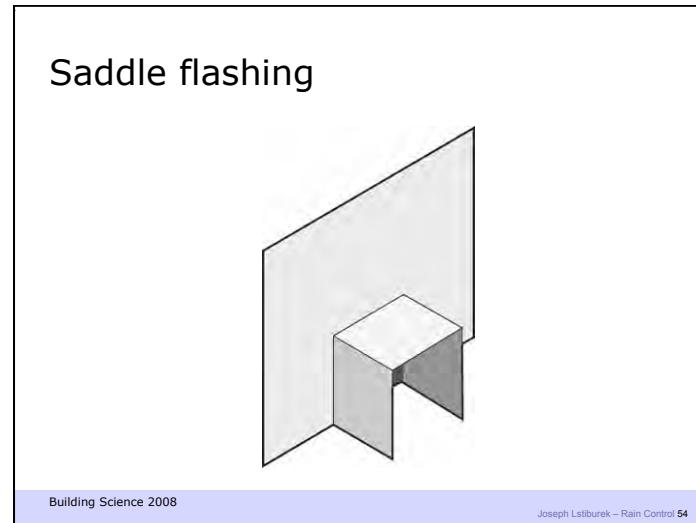
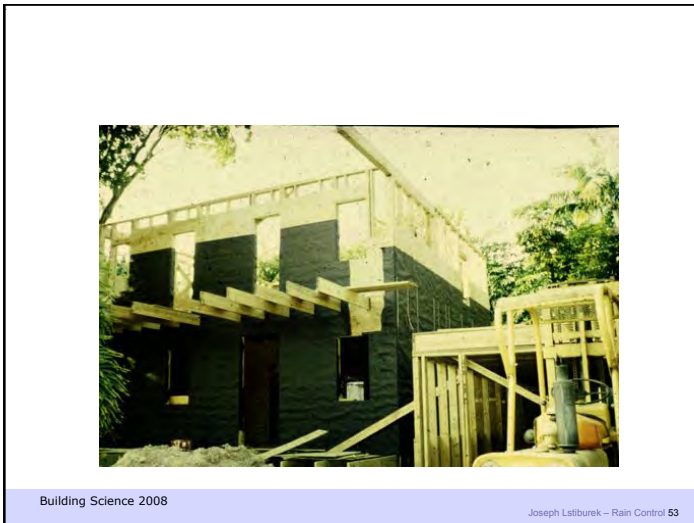

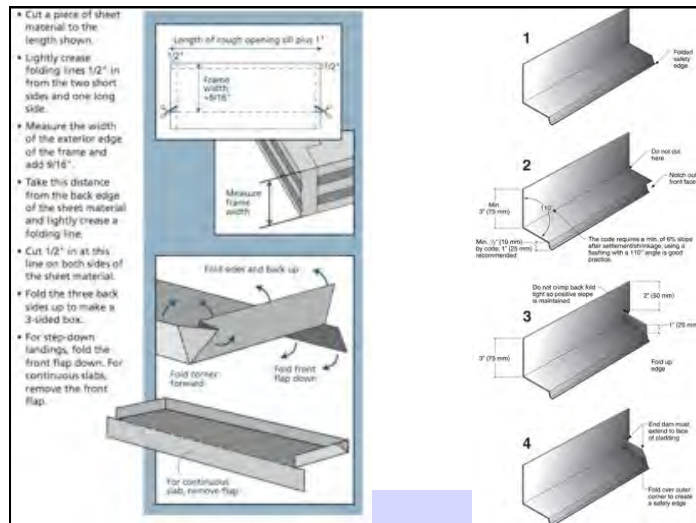
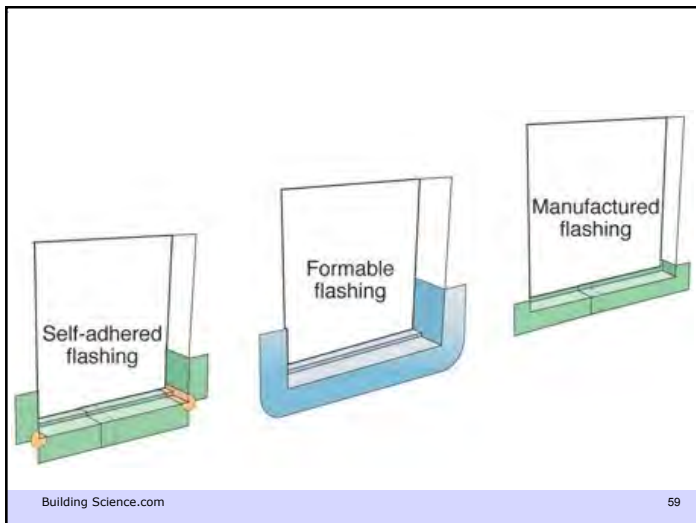
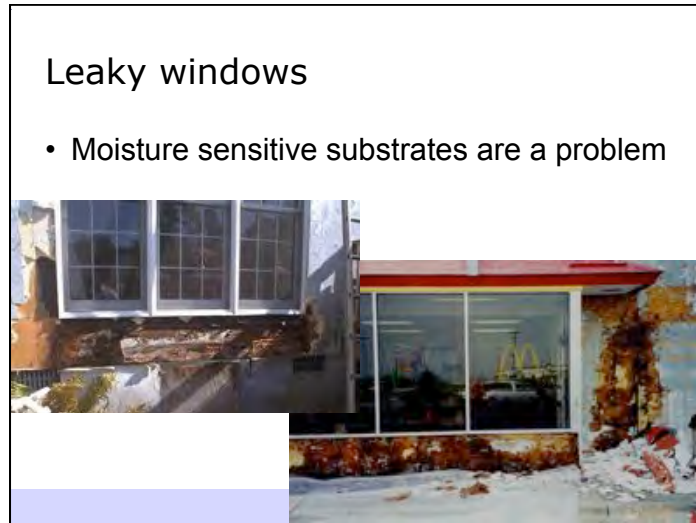

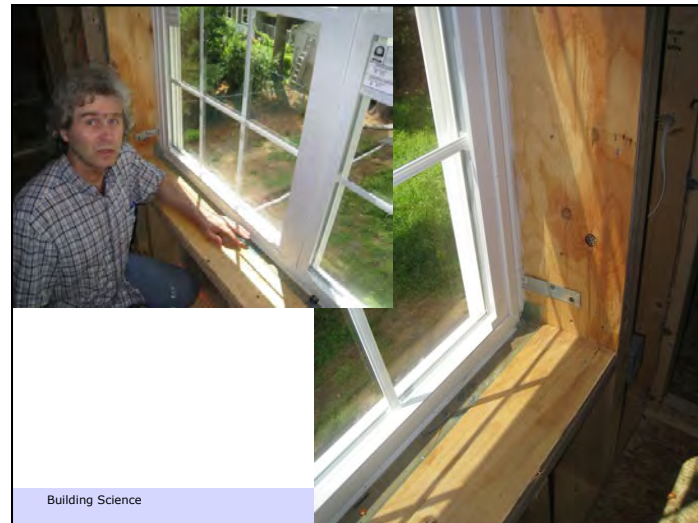
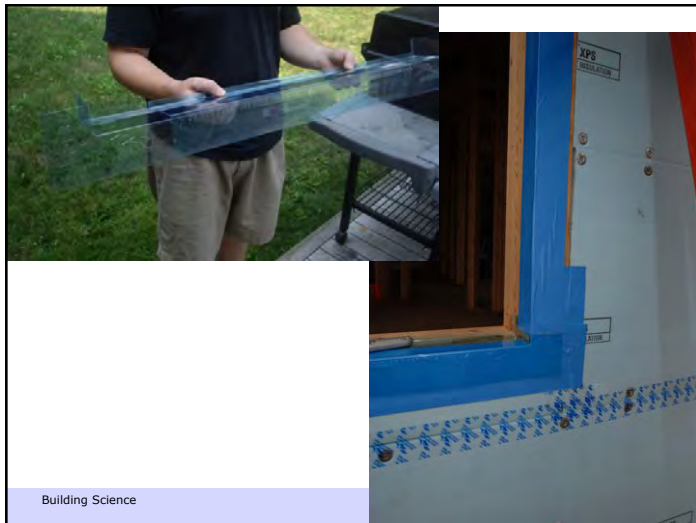
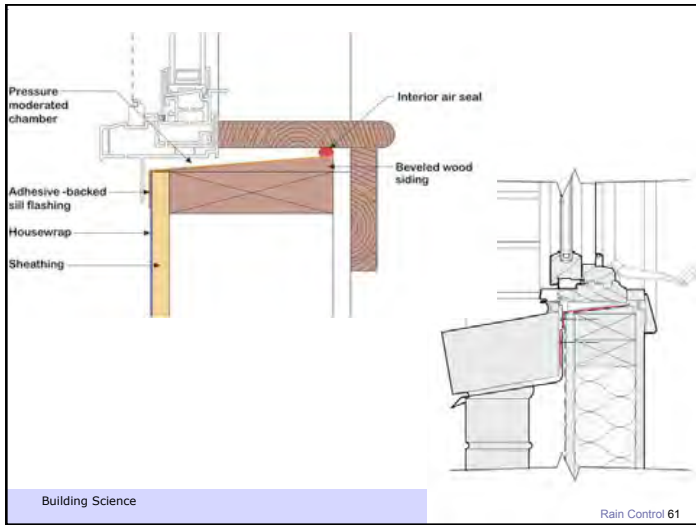

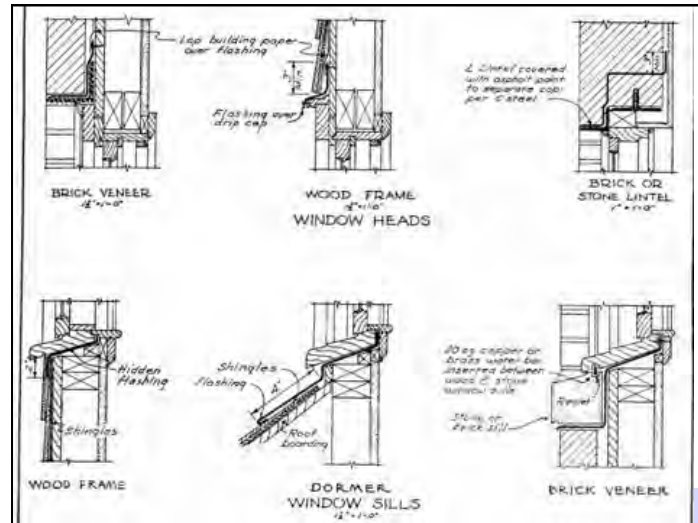

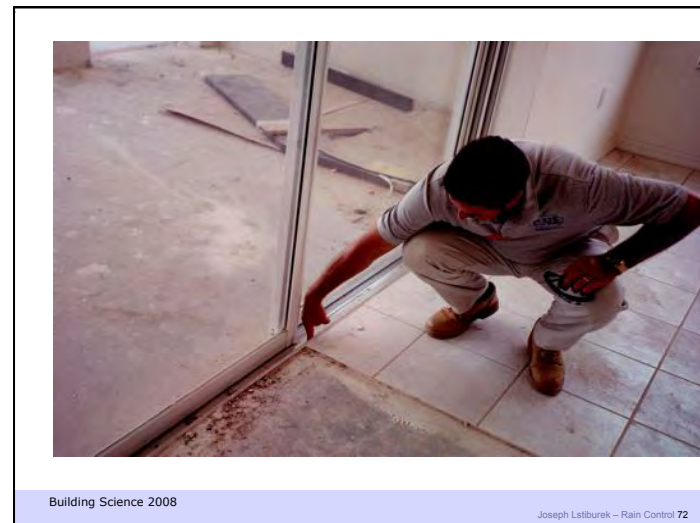
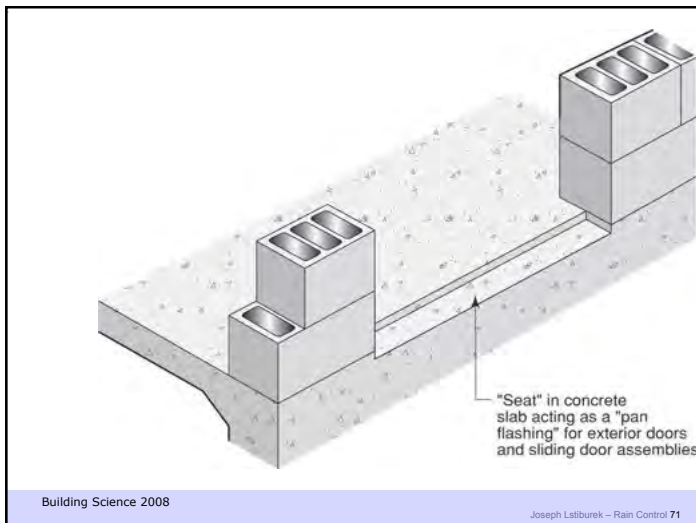
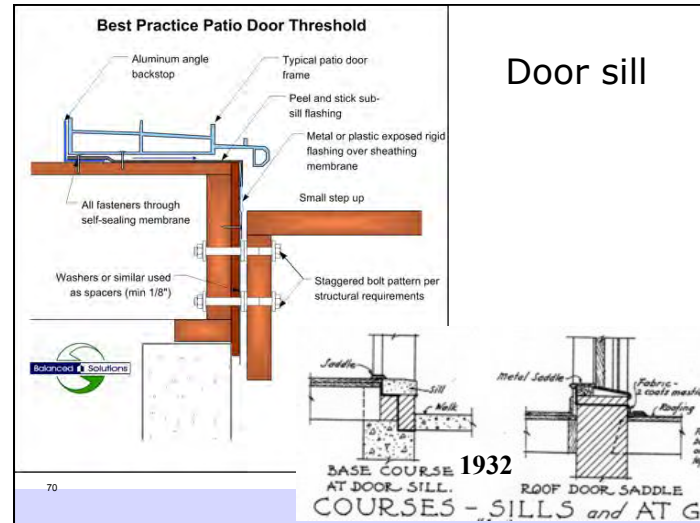

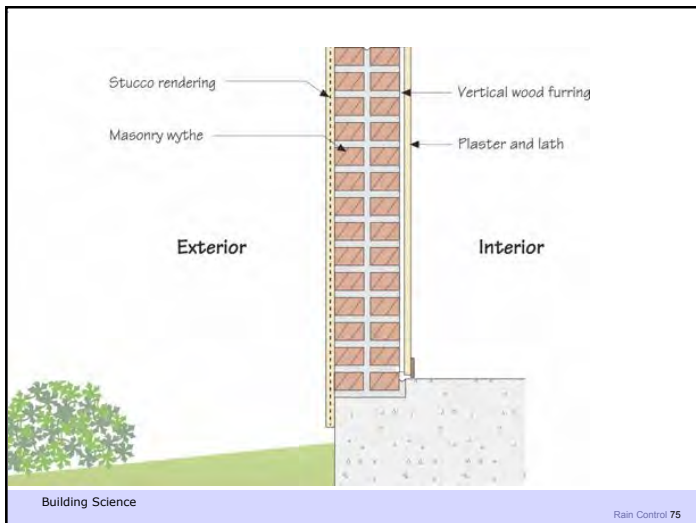
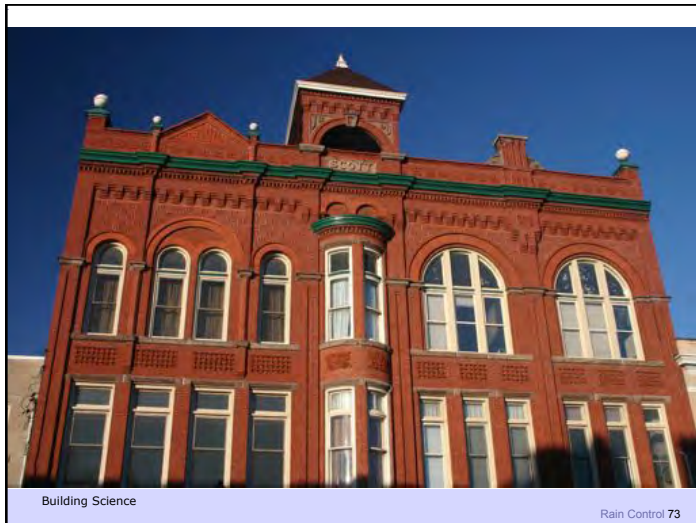

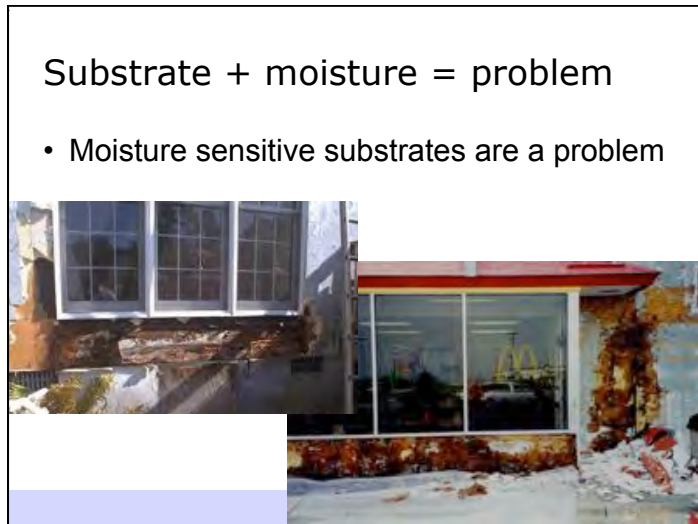
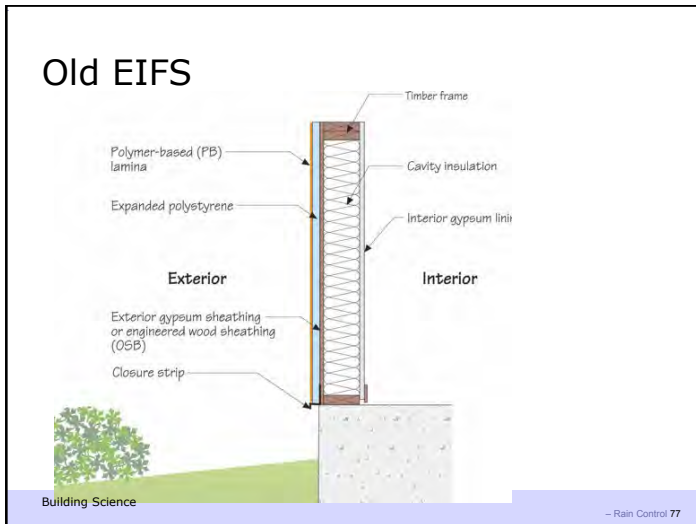

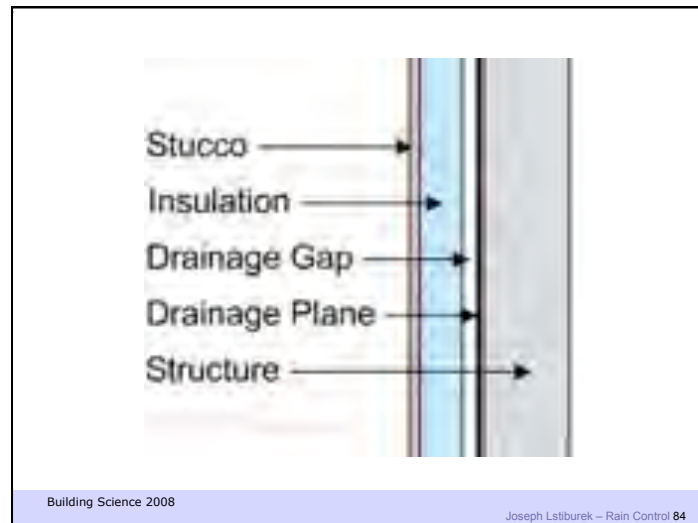
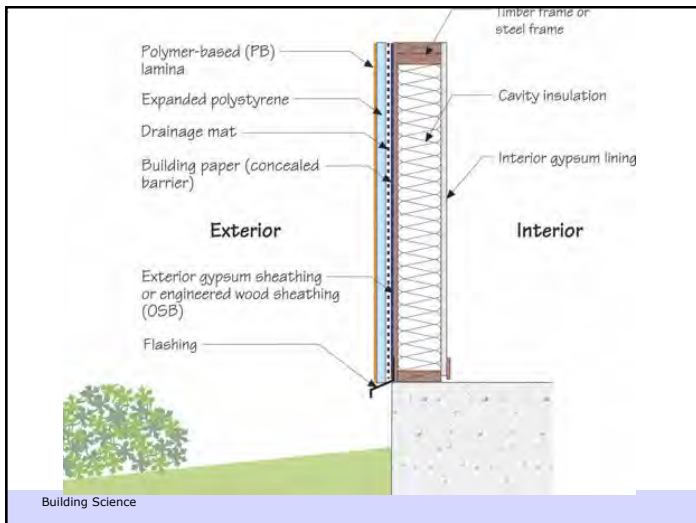



Conclusions

- Drainage is the key, cladding leaks
- All penetrations need to be drained!
- Beware flashing, it needs to waterproof
- Understand older systems are different