

NEXUS
Green Round Table

April 28, 2007

INSULATION

Peter Baker, P.Eng.
Building Science Consulting
www.buildingscience.com

Presentation Overview

Part I: Insulation and Energy Transfer Basics

Basic Heat Flow

Energy Transfer In Buildings

What Insulation Does

Performance Factors

Part II: Insulation and Sustainable Design

Building Sustainability

Materials

Embodied Energy

The Right Stuff

PART I: INSULATION AND ENERGY TRANSFER BASICS

Basic Heat Flow

Conduction

Convection

Radiation

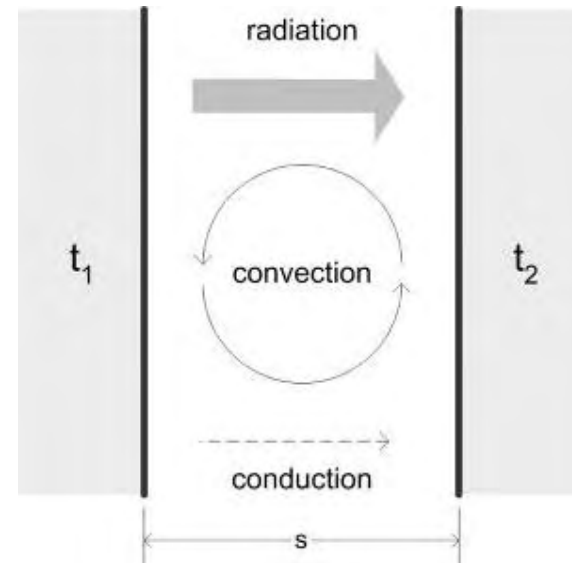

Basic Heat Flow

Conduction

- Heat Flow by direct contact
- Vibrating molecules
- Most important for solids

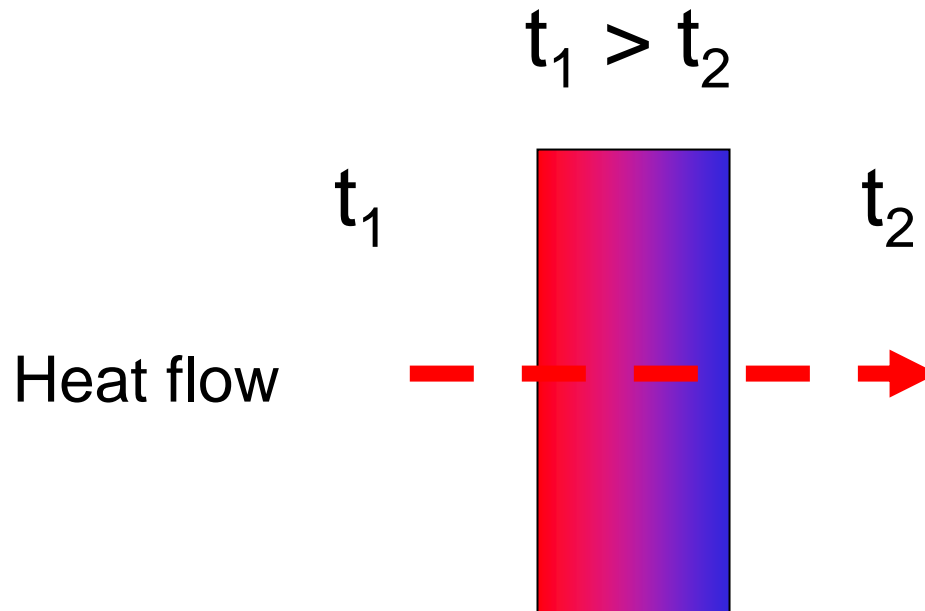

Basic Heat Flow

Forced Convection

- Heat Flow by bulk movement of molecules
- Most important for liquids and gases
- Movement driven by fans or wind

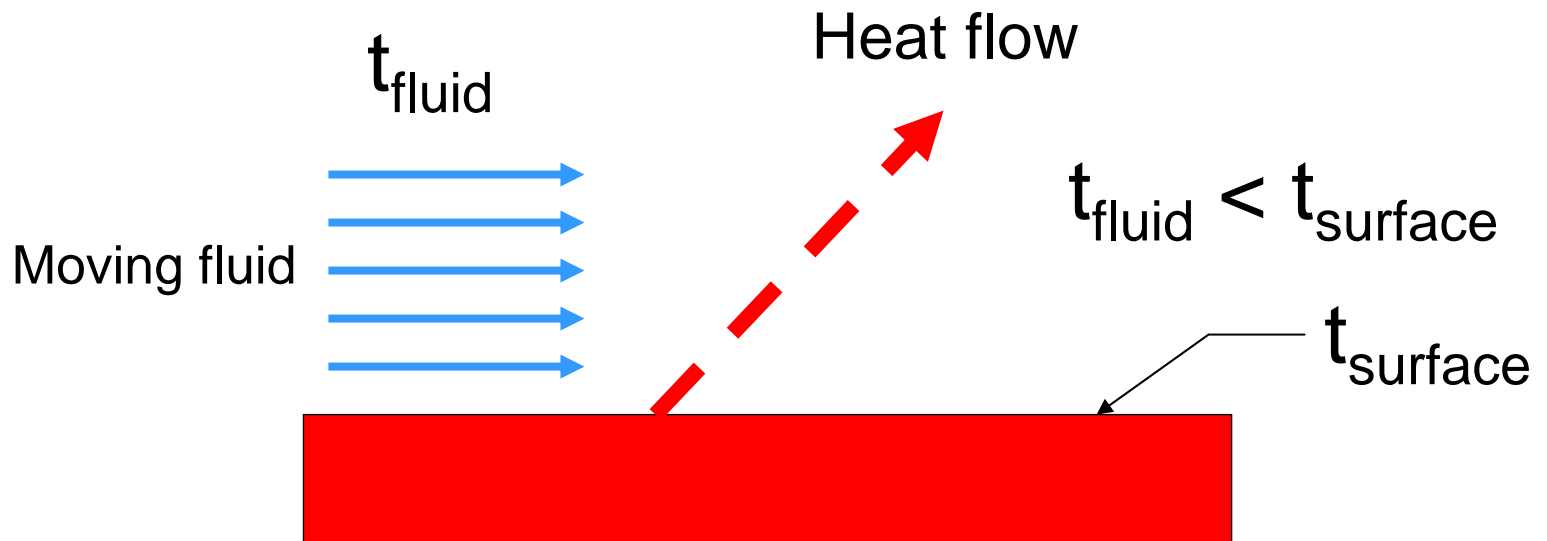

Basic Heat Flow

Natural Convection

- Heat Flow by bulk movement of molecules
- Most important for liquids and gases
- Natural buoyancy drives movement

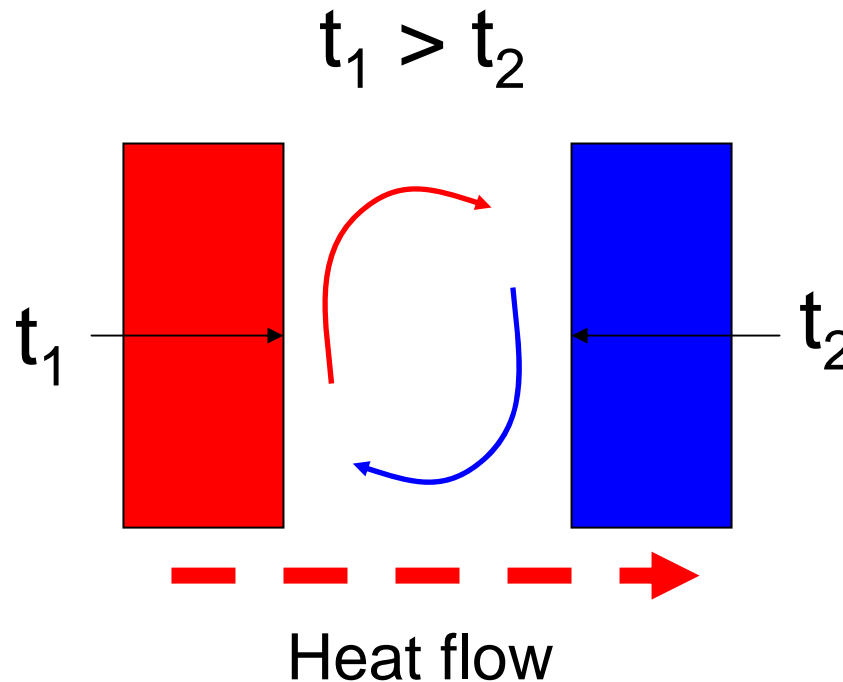

Basic Heat Flow

Radiation

- Heat flow by electromagnetic waves
- Heat radiates from all materials, e.g. campfire
- Passes through gases and vacuum (NOT Solid)

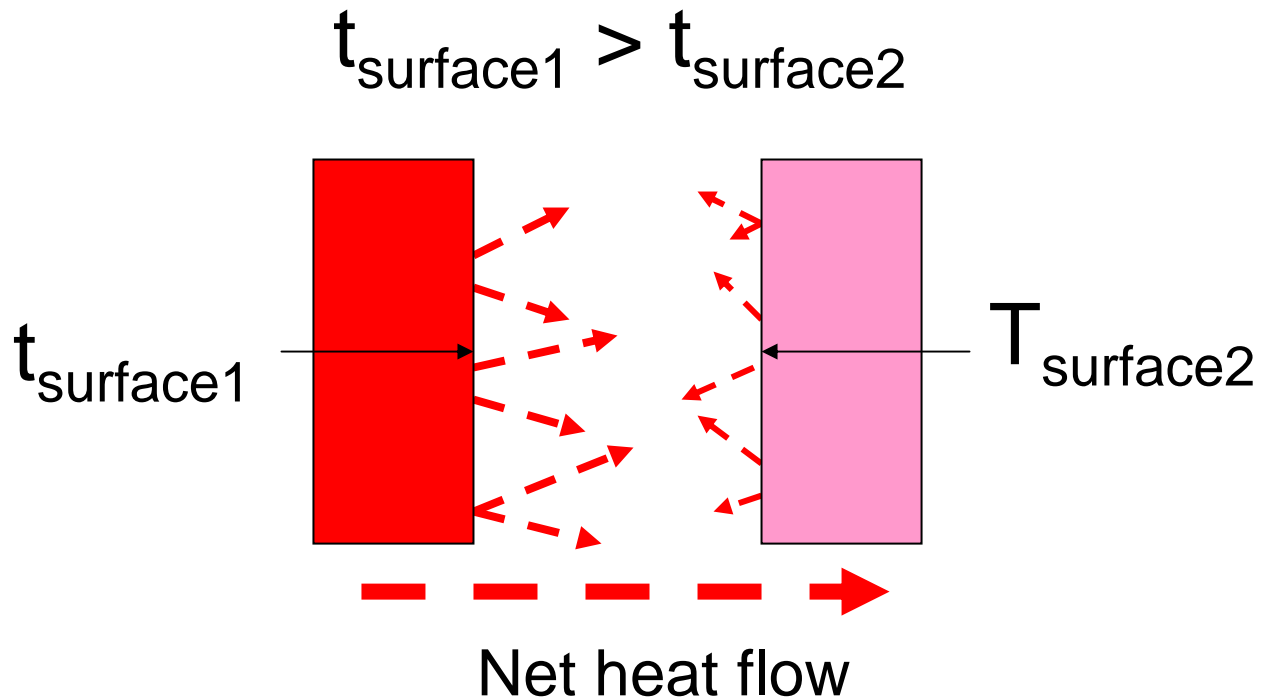

Energy Transfer in Buildings (no windows)

Conduction through the enclosure

Convection through the enclosure

Convection within the enclosure assemblies

Radiation within the enclosure assemblies

Conduction through the enclosure

Most common metric is “R-value”
 The R-value is a measure thermal resistance

Total thermal resistance R_T is a sum of the thermal resistance of all the materials in the enclosure assembly.

Materials such as gypsum, plywood, OSB, wood studs, metal studs all contribute to the overall thermal conduction resistance.

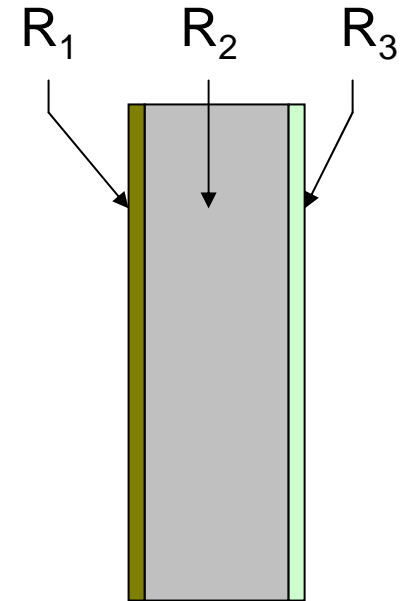

$$R_T = R_1 + R_2 + R_3$$

Conduction through the enclosure

Materials of lower thermal resistance create pathways of increased conductive losses, or “thermal bridges” through layers of greater thermal resistance

Thermal bridging can reduce the effective R-value of a wall assembly.

A 2x6 wood stud wall 16” OC with R-19 Fiberglass Batt = effective R-13 wall assembly.

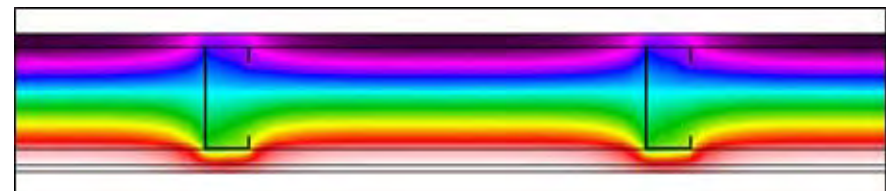
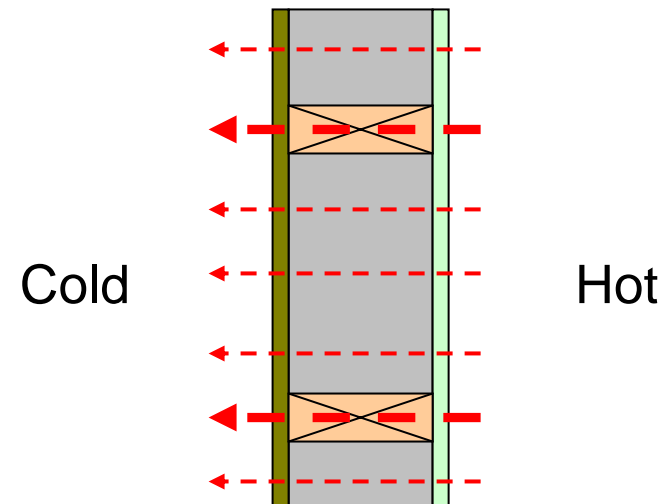

Conduction through the enclosure

Steel is 400 times more
conductive than wood

Steel studs are about
40 times thinner

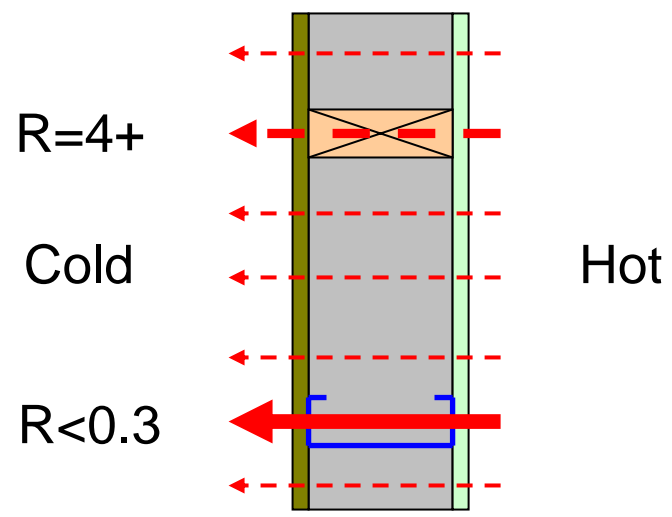

Convection through the enclosure

Commonly referred to as “Air Leakage”

Driven by air pressure differences

- wind
- mechanical
- stack effect

Large energy impacts (can account for 30% of the heating and cooling energy)

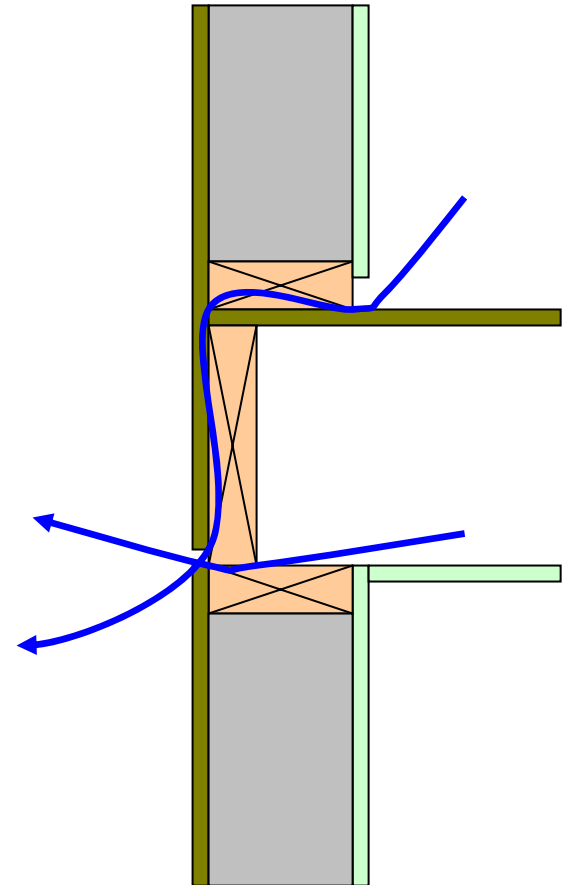

Convection within the enclosure assemblies

Commonly referred to as
“Convective Loops”

Driven by natural buoyancy - warm
air will rise

Short circuits insulation

R-value does not take into account
the potential of movement of air
within an assembly.

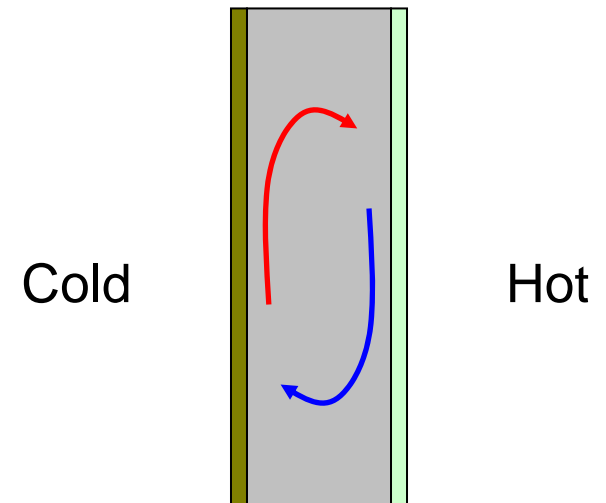

Radiation from surfaces within the enclosure assemblies

Net radiant flow across a clear cavity

Emissivity is expressed as a fraction of energy emitted when compared to the radiation from a black body

Common in attics

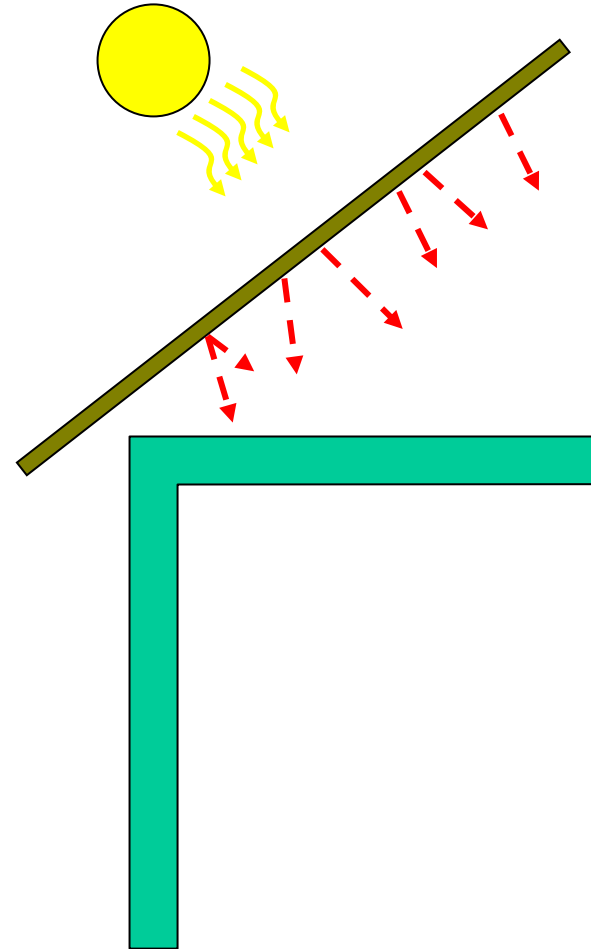

What Insulation Does

Primary

- Reduce conductive transfer

Possible Secondary

- Control air leakage (moisture and energy concerns)
- Control convective loops
- Reduce radiation transfer within an enclosure assembly
- Control vapor (diffusion, condensing surface temperature)

Materials

Thermal conductivity (& resistance) varies with

- material type (conduction, radiation)
- density and pore structure
- moisture content
- temperature difference

Combination of insulation of air + material

Still air is about R6/inch ($k=0.024$ W/mK)

Only gas fills (e.g. HCFC) can improve this

Materials

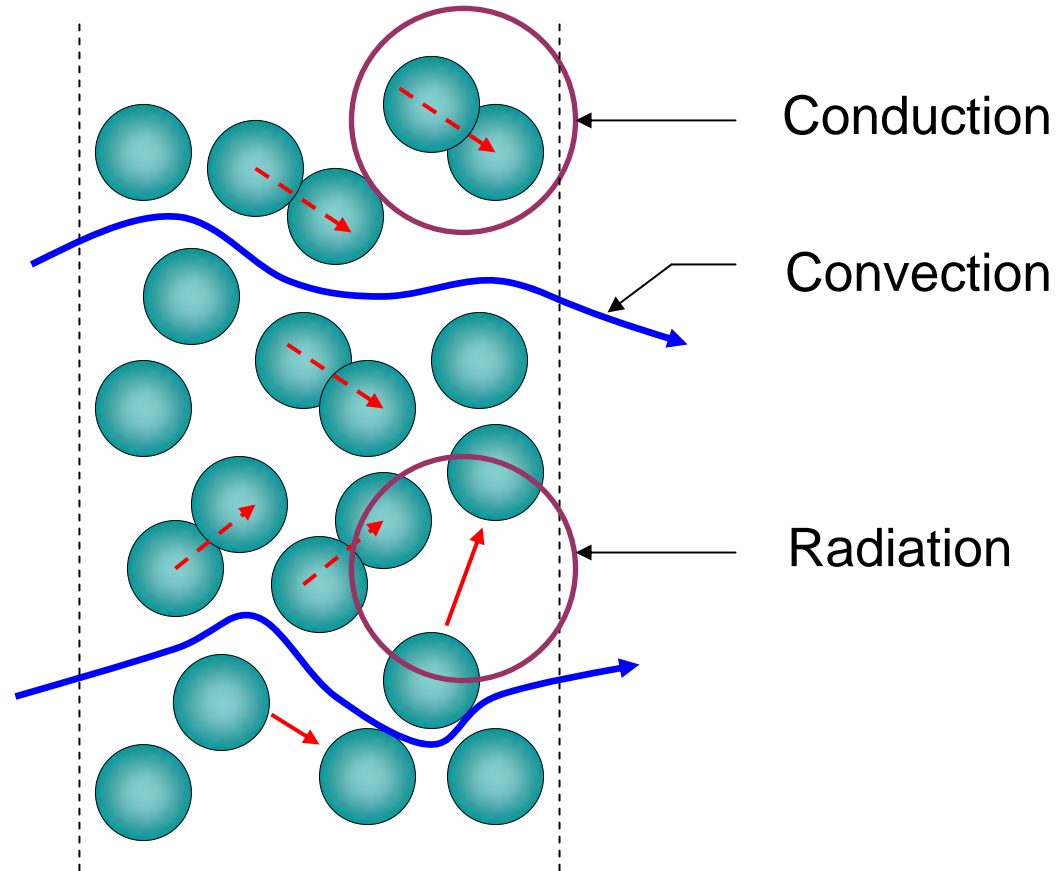

Hypothetical porous material

Performance Factors

Thermal Resistance (R-value)

Air Impermeability

Vapor Permeability

Moisture Resistance

Installation

Insulation Types

Cavity

- Mineral Fiber Batts
- Blown/Spray Mineral Fiber
- Blown/Spray Cellulose
- Cotton
- Open Cell Spray Polyurethane
- Closed Cell Spray Polyurethane

Insulating Sheathing

- Medium Density Mineral Fiber
- Expanded Polystyrene
- Extruded Polystyrene
- Polyisocyanurate
- Closed Cell Spray Polyurethane

Performance

Mineral Fiber Batts (Glass/Rock/Slag)

- R/inch = 2.8 to 3.7
- Air Permeable
- Vapor Permeable
- No moisture storage capacity
- Uneven cavity fill (difficult to fit around obstructions)

Blown/Spray Mineral Fiber (Glass/Rock/Slag)

- R/inch = 2.8 to 3.7
- Air Permeable
- Vapor Permeable
- No moisture storage capacity
- Even Cavity Fill (net/adhesive holds fibers in place)



Performance

Blown/Spray Cellulose

- R/inch = 3.0 to 3.7
- Air Permeable (higher density = some resistance to air flow)
- Vapor Permeable
- Some moisture storage capacity
- Even Cavity Fill (net/adhesives hold fibers in place)

Cotton

- R/inch = 3.0 to 3.7
- Air Permeable (Some resistance to air flow)
- Vapor Permeable
- Some Moisture Storage Capacity
- Even Cavity Fill



Performance

Open Cell Spray Polyurethane

- R/inch = 3.6 to 3.8
- Air Impermeable (good air barrier <0.01 lps/m² @ 75 Pa, controls convective loops)
- Vapor Permeable
- Moisture Resistant
- Even Cavity Fill (expands to fill voids)

Closed Cell Spray Polyurethane

- R/inch = 5.8 to 6.8
- Air Impermeable (good air barrier <0.01 lps/m² @ 75 Pa, controls convective loops)
- Vapor Semi-impermeable (1 – 2 perms for 2” thickness)
- Moisture Resistant
- Even Cavity Fill (expands to fill voids)



Performance

Medium Density Mineral Fiber (Glass/Rock/Slag)

- R/inch = 4.0 to 4.4
- Air Permeable (resistance to wind washing)
- Vapor Permeable
- Moisture Resistant (good drainage for rock/slag)

Expanded Polystyrene

- R/inch = 3.6 to 4.4
- Air Impermeable (air barrier if joints taped?)
- Vapor Semi-impermeable (3 – 4 perms)
- Moisture Resistant



Performance

Extruded Polystyrene

- R/inch = 5.0
- Air Impermeable (air barrier if joints taped?)
- Vapor Semi-impermeable (0.5 perms for 2" thickness)
- Moisture Resistant

Polyisocyanurate

- R/inch = 6.0 to 6.5
- Air Impermeable (air barrier if joints taped?)
- Vapor Semi-Impermeable or Impermeable (<1 glass fiber faced, 0.03 perms for foil faced)
- Moisture Resistant



Performance

Closed Cell Spray Polyurethane

- R/inch = 5.8 to 6.8
- Air Impermeable (good exterior air barrier system <0.01 lps/m² @ 75 Pa)
- Vapor Semi-impermeable (1 - 2 perms for 2" thickness)
- Moisture Resistant (can act as a drainage plane behind a cladding system)



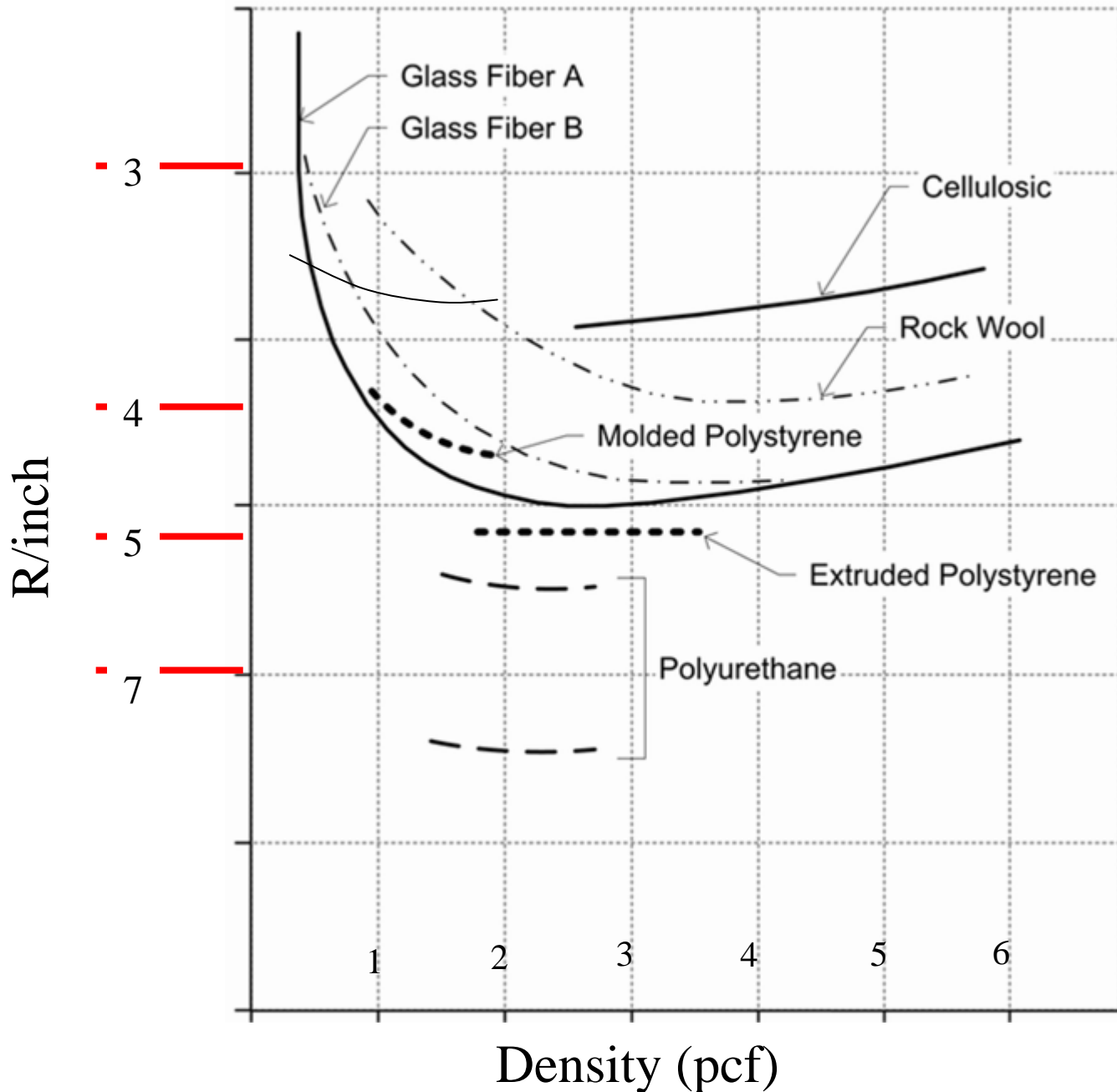



bsc Performance

R-value Air Permeability Vapor Permeability Moisture Resistance Installation

Cavity Insulation

	R-value	Air Permeability	Vapor Permeability	Moisture Resistance	Installation
Mineral Fiber Batts	2.8 to 3.7	Permeable	Permeable	No Storage	Un-even fill
Blown/Spray Mineral Fiber	2.8 to 3.7	Permeable	Permeable	No Storage	Even fill
Blown/Spray Cellulose	3.0 to 3.7	Permeable	Permeable	Some Storage	Even fill
Cotton	3.0 to 3.7	Permeable	Permeable	Some Storage	Even fill
Open Cell Spray Polyurethane	3.6 to 3.8	Impermeable	Permeable	Resistant	Even fill
Closed Cell Spray Polyurethane	5.8 to 6.8	Impermeable	Semi-Impermeable	Resistant	Even fill

Insulation Sheathing

	R-value	Air Permeability	Vapor Permeability	Moisture Resistance	Installation
Medium Density Mineral Fiber	4.0 to 4.4	Permeable	Permeable	Resistant	
Expanded Polystyrene	3.6 to 4.4	Impermeable	Semi-Permeable	Resistant	
Extruded Polystyrene	5.0	Impermeable	Semi-Impermeable	Resistant	
Polyisocyanurate	6.0 to 6.5	Impermeable	Impermeable	Resistant	
Closed Cell Spray Foam	5.8 to 6.8	Impermeable	Semi-Impermeable	Resistant	

PART II: INSULATION AND SUSTAINABLE DESIGN

The Big Picture

Lifespan of a building is long

Upgrading enclosure assemblies is difficult and expensive after construction of the building

Maximize thermal efficiency of the enclosure for long term building sustainability

INSULATION IS OUR FRIEND!!!

Building Sustainability (short list)

1. Durability

2. Energy Consumption Reduction

3. Materials

Materials

Fiberglass

- Silica sand
- Often contains recycled glass (20% to 30%)
- Phenol formaldehyde or acrylic binders
- Concern regarding formaldehyde as a known carcinogen
- Fibers are an irritant

Rock/Slag

- Blast furnace slag/basalt rock
- Slag is a waste product from steel production
- Phenol formaldehyde or acrylic binders (less used compared to fiberglass)
- Fibers are an irritant
- Not as readily available

Materials

Cellulose

- Recycled newsprint
- Ammonium sulfate or borate fire retarders (borate recommended – less harmful + mold inhibitor as well)
- Fibers are an irritant
- VOC's from ink (most inks are now vegetable based)

Cotton

- 85% recycled denim and polyester fibers
- Ammonium sulfate or borate fire retarders (borate recommended – less harmful + mold inhibitor as well)
- Two manufacturers
- Not as much experience

Expanded Polystyrene

- Petrochemical (natural gas/petroleum)
- Can contain recycled content (up to 60%)
- Created by reacting benzene with ethylene
- Pentane blowing agent (non ozone depleting)
- Residual styrene monomer a concern
- Brominated HBCD – fire retardant (possible bioaccumulation – toxic)

Extruded Polystyrene

- Petrochemical (natural gas/petroleum)
- Can contain recycled content (up to 15%)
- Created by reacting benzene with ethylene
- HCFC blowing agent (only remaining ozone depleting blowing agent for plastic foams)
- Residual styrene monomer a concern
- Brominated HBCD – fire retardant (possible bioaccumulation – toxic)

Materials

Polyisocyanurate

- Petrochemical (natural gas/petroleum)
- Can contain recycled content (9% to 10% from plastic bottles)
- Foil Facing can contain recycled content
- Created by reacting isocyanate with polyol
- Pentane blowing agent (non ozone depleting)
- TCPP – fire retardant (less bioaccumulative than HBCD)

Open Cell Spray Polyurethane

- Petrochemical (natural gas/petroleum)
- Created by reacting isocyanate with polyol
- Can replace 40% of polyol with soy oil (25% soy based final product)
- Water is the blowing agent
- VOC, during and after install – flush out period recommended
- Non-brominated fire retardant (TCPP – chlorine, RDP – halogen free)

Closed Cell Spray Polyurethane

- Petrochemical (natural gas/petroleum)
- Created by reacting isocyanate with polyol
- HFC-245fa blowing agent (non-ozone depleting)
- 3 to 4 times material use compared to Open Cell Spray Polyurethane
- VOC, during and after install – flush out period recommended
- Non-brominated fire retardant (TCPP – chlorine, RDP – halogen free)

Embodied Energy

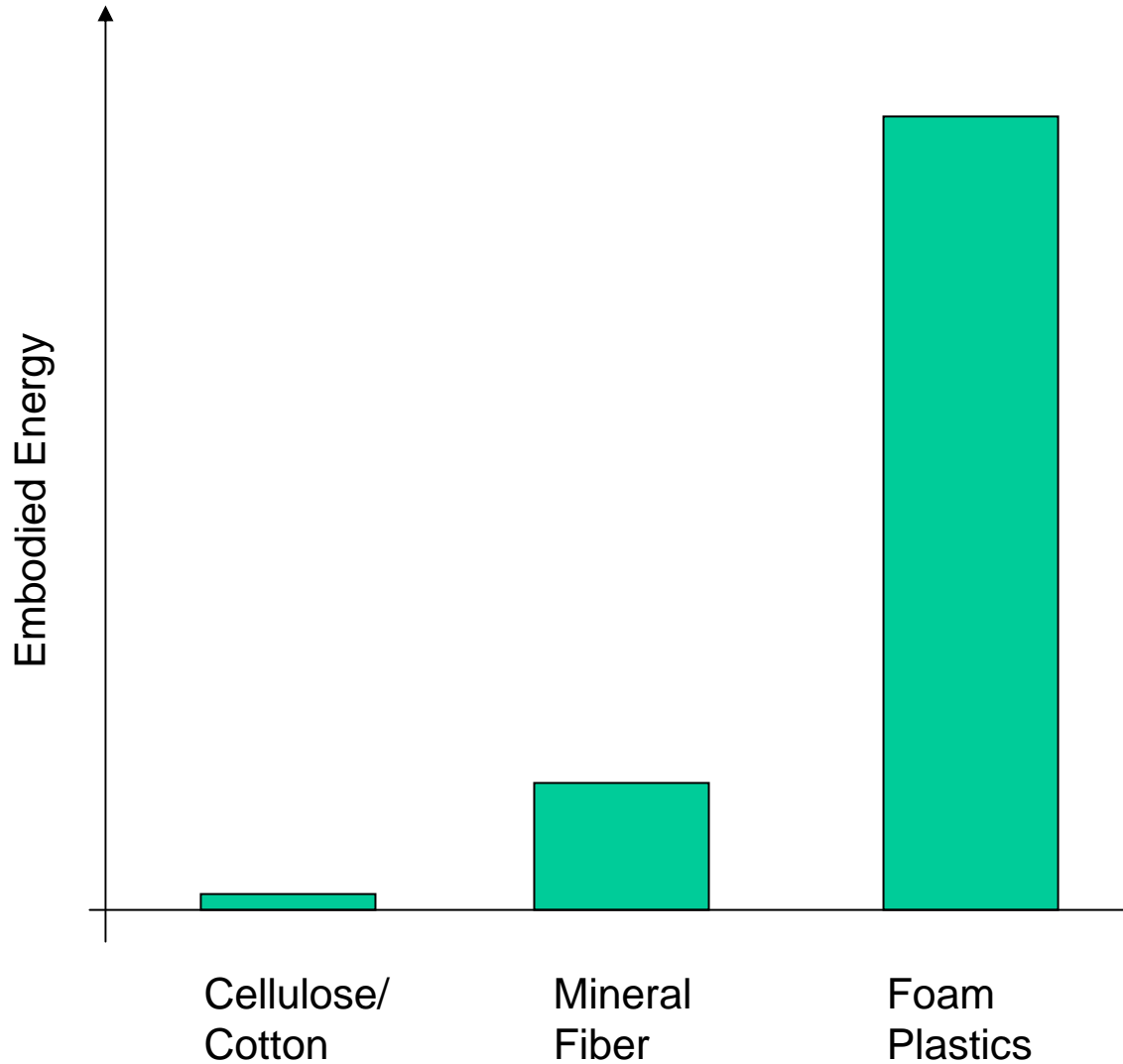

Embodied Energy

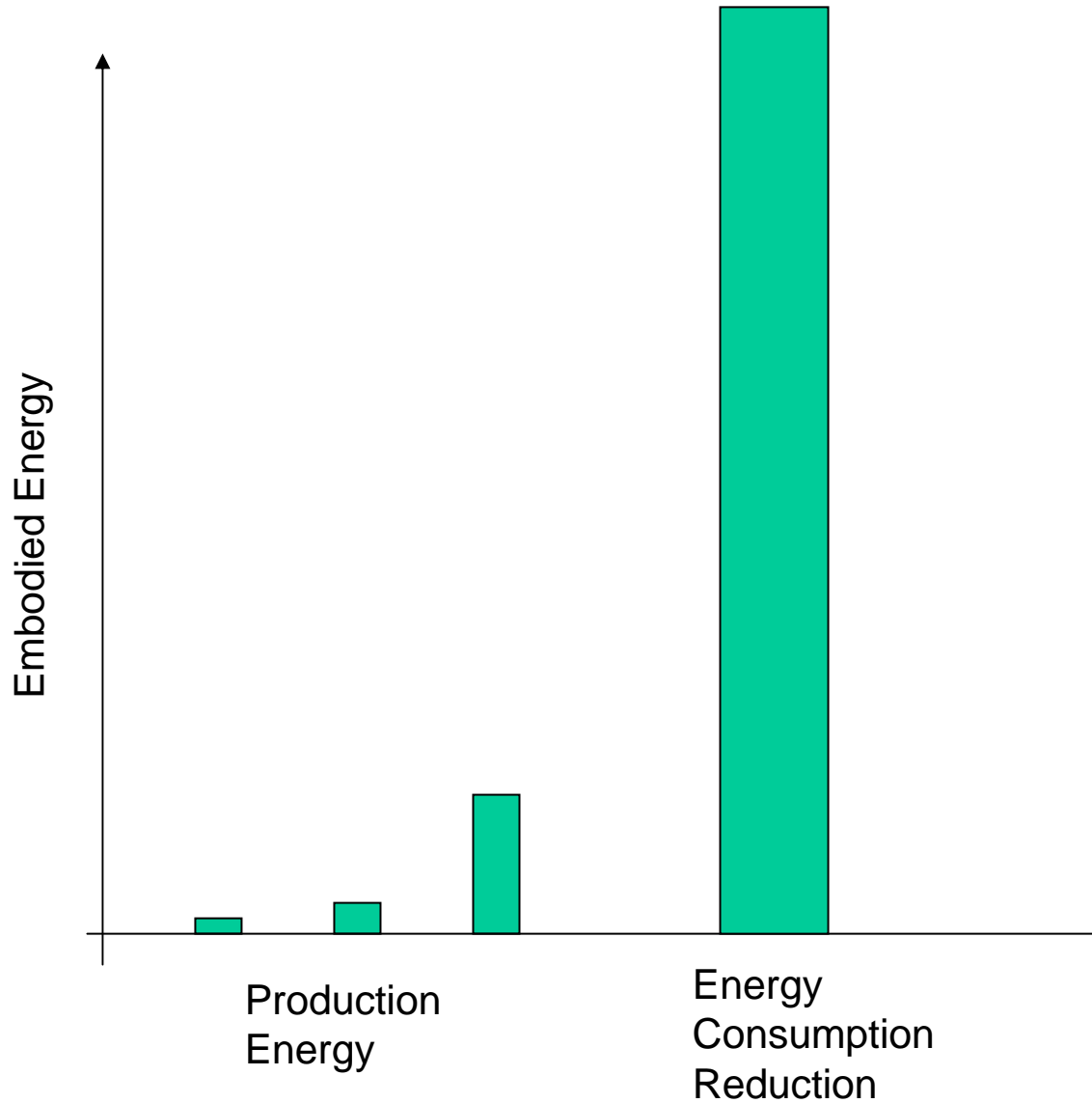

Embodied Energy

At this stage, the energy savings gained from a well insulated building are significantly higher than the energy consumption used to produce the insulating material

Reality Check

Cost and availability are real factors in the actual construction of a building. Buying less “green” insulation is potentially more harmful than properly insulating with less sustainable products.

The Right Stuff

The key is to understand the properties of the various available materials and choose the best materials available to manage the moisture and energy flow through the enclosure assemblies, to ensure long term energy performance as well as building durability.

Choosing a suite of materials to be assembled in a system can lead to very high performance enclosure designs

The Right Stuff

Minimize thermal bridging through efficient use of materials

- Advanced framing - fewer thermal bridges = less energy loss
- Completely and evenly fill the stud cavity space
- Use of cavity insulation with highly conductive framing (metal studs) is not recommended

The Right Stuff

Add as much insulation as is practical

- Insulating sheathing can add significant increases in insulation levels with minimal disruption to standard construction practices
- In cold climates, insulating sheathing also helps control moisture problems by increasing the condensing surface temperature in the wall cavity.
- Use moisture resistant materials in any location where water exposure is expected.

The Right Stuff

Increase the air tightness of the enclosure

- Spray foam insulation materials provide for excellent air sealing
- Complete filling of cavities with spray polyurethane will eliminate convective loops
- Using higher density blown/sprayed mineral fiber, cellulose, or cotton, will reduce the potential for convective loops.

The Right Stuff

2x6 Wall (23% framing fraction)

Element	Cavity	Stud
Outside Air Film	0.17	0.17
1/2" Plywood	0.62	0.62
2x6 Wood Stud	n/a	5.83
5.5" Fiberglass Batt	19	n/a
1/2" Interior Gypsum	0.45	0.45
Interior Air Film	0.68	0.68
Total	20.92	7.75

$$R_{\text{effective}} = 14.42$$

The Right Stuff

2x6 Wall (16% framing fraction – Advanced Framing)

Element	Cavity	Stud
Outside Air Film	0.17	0.17
1/2" Plywood	0.62	0.62
2x6 Wood Stud	n/a	5.83
5.5" Fiberglass Batt	19	n/a
1/2" Interior Gypsum	0.45	0.45
Interior Air Film	0.68	0.68
Total	20.92	7.75

$$R_{\text{effective}} = 15.88$$

2x6 Wall (16% framing fraction – Advanced Framing)

Element	Cavity	Stud
Outside Air Film	0.17	0.17
1" Medium Density Mineral Fiber	4	4
1/2" Plywood	0.62	0.62
2x6 Wood Stud	n/a	5.83
5.5" Fiberglass Batt	19	n/a
1/2" Interior Gypsum	0.45	0.45
Interior Air Film	0.68	0.68
Total	24.92	11.75

$$R_{\text{effective}} = 19.88$$

2x6 Wall (16% framing fraction – Advanced Framing)

Element	Cavity	Stud
Outside Air Film	0.17	0.17
1.5" XPS	7.5	7.5
1/2" Plywood	0.62	0.62
2x6 Wood Stud	n/a	5.83
5.5" Fiberglass Batt	19	n/a
1/2" Interior Gypsum	0.45	0.45
Interior Air Film	0.68	0.68
Total	28.42	15.25

$$R_{\text{effective}} = 23.38$$

2x6 Wall (16% framing fraction – Advanced Framing)

Element	Cavity	Stud
Outside Air Film	0.17	0.17
2" Polyisocyanurate	13	13
1/2" Plywood	0.62	0.62
2x6 Wood Stud	n/a	5.83
5.5" Fiberglass Batt	19	n/a
1/2" Interior Gypsum	0.45	0.45
Interior Air Film	0.68	0.68
Total	33.92	20.75

$$R_{\text{effective}} = 28.88$$

The Right Stuff

2" of insulating sheathing to add additional thermal resistance, protect the drainage plane, and help control the condensing surface temperature of the exterior sheathing.

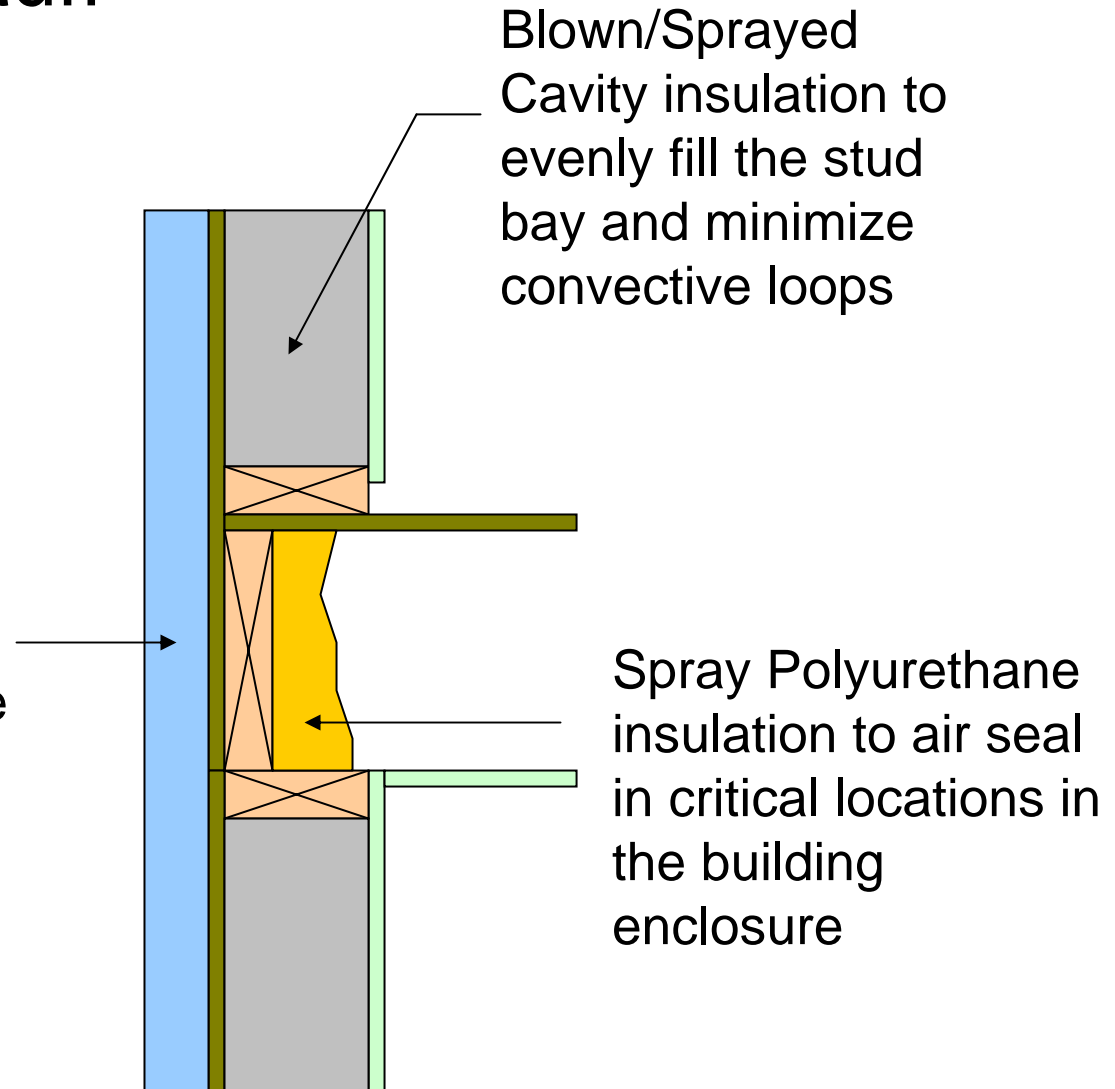

The Right Stuff

2" of insulating sheathing to add additional thermal resistance, protect the drainage plane, and help control the condensing surface temperature of the exterior sheathing.

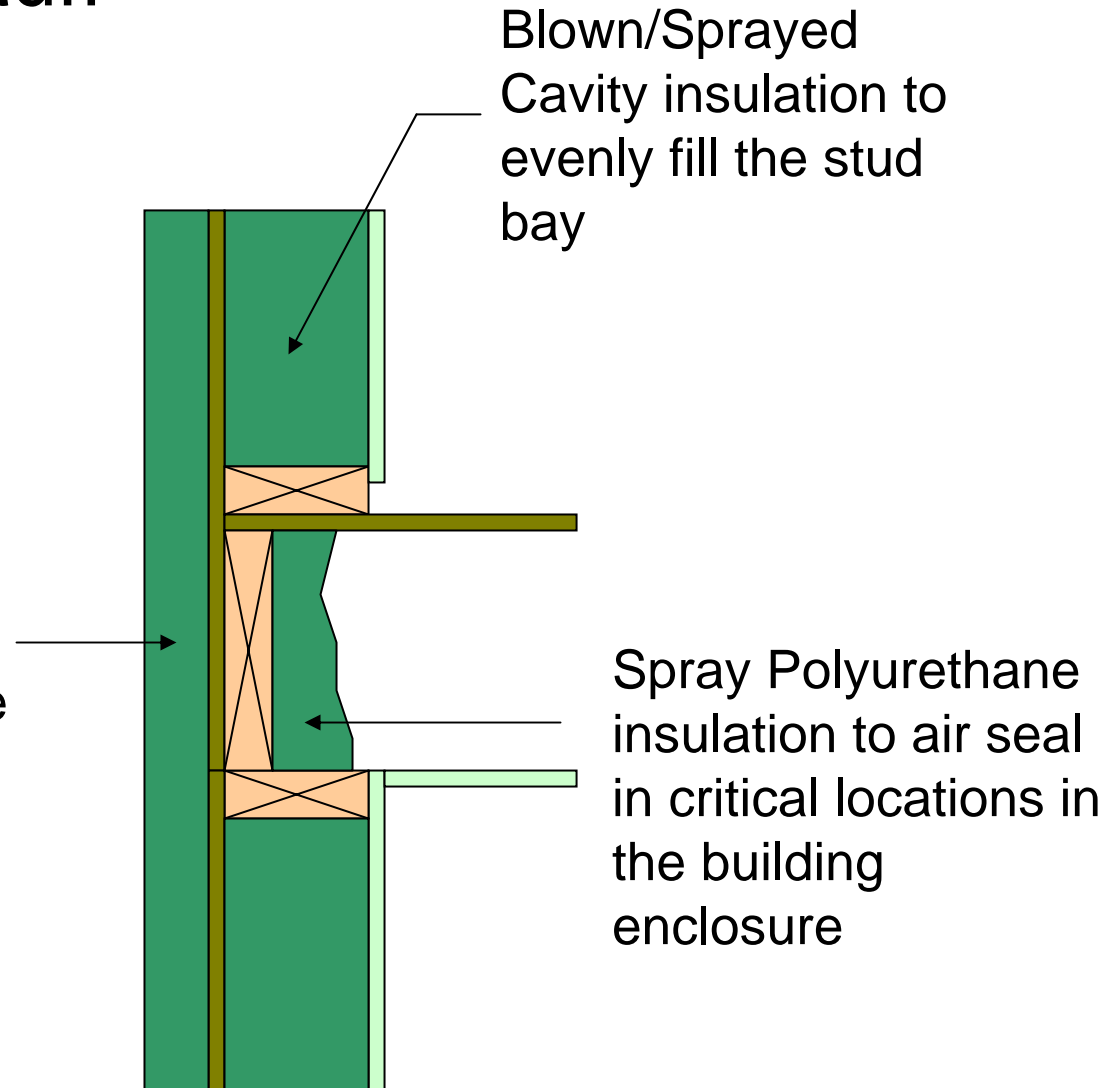

Resources

This presentation will be at

- www.BuildingScienceSeminars.com

Much more free downloadable info at

- www.BuildingScience.com